

**MUELLER 2300 Series Resilient Wedge Gate Valves**

Mueller Resilient Wedge Gate Valves have features to make them easier to operate, preserve sealing capability, and interior coating integrity for many years of reliable service. In addition to popular end connection options, Mueller brand RW valves can be ordered with Mueller's exclusive AquaGrip® System that incorporates an o-ring sealed compression connection and integral pipe restraint in one "ready to use" easy and quick to install package.

**Mueller 4" – 12" 2361 Series Resilient Wedge Gate Valve Features**

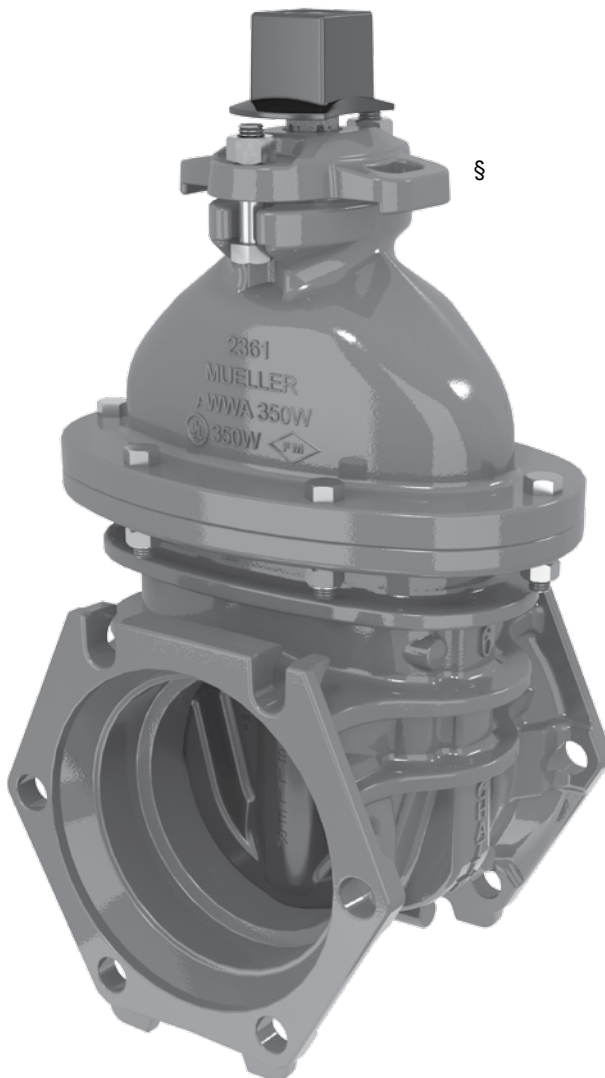

- 350 PSIG (2400 kPa/24 barg) MAXIMUM WORKING PRESSURE – Hydrostatically tested at 700 psig (4800 kPa/48 barg).
- DUAL-PURPOSE LIFTING LUGS – new dual-purpose lifting lugs provide stability for the valve box. Accommodates strap or hooks; provides valve box alignment, eliminating need for valve box adapter.
- AMERICAN MADE QUALITY – factory in Chattanooga, TN with ISO 9001 certification. Certified to ANSI/NSF 61 & 372. Manufactured and tested in compliance with ANSI/AWWA Standard C515. UL 262 Listed and FM 1120/1130 Approved.
- DUCTILE IRON - Valve body, bonnet, disc, stuffing box, and op nut.
- T-HEAD BOLT RETENTION – improved T-head bolt retention feature eliminates need for anti-rotation bolts.
- TRIPLE O-RING SEALS – two above thrust collar and one below, retain lubricant in this critical area. Top two are replaceable with valve fully open and under pressure. Fourth O-ring serves as dirt seal.
- TWO ANTI-FRICTION WASHERS WITH LUBRICATION – made of polymer, one above and one below the thrust collar, reduce operating torque to open or close valve.
- STEM – forged manganese bronze bar stock is upset, then machined to form a thrust collar for superior strength in this critical area.
- GUIDE CAP BEARINGS – made of polymer and snapped over rubber covered wedge guides, provide bearing surfaces that protect both wedge and interior body coating from wear and aid in easy operation – even the largest valves installed horizontally. Rollers, tracks and scrapers are not needed.
- SMOOTH, OVERSIZED FLOW WAY – full, round, unobstructed flow way accommodates full size cutters, provides superior flow characteristics and reduces pumping costs.\*\*
- MUELLER PRO-GARD® FUSION BONDED EPOXY COATING – 10 mils\* thick protects all inside and outside iron surfaces, and complies with AWWA C550.
- INTEGRAL LEGS – stands upright for easier handling and storage.
- 10-YEAR LIMITED WARRANTY – assured reliability (see separate Mueller Warranty document for terms).
- MUELLER VALVES ARE DESIGNED FOR POTABLE WATER APPLICATIONS.

\*Nominal

\*\*16" valve requires 1/2" undersized cutter, 54" valve requires 48" cutter

**Mueller 14" – 54" 2361 Series Resilient Wedge Gate Valve Features**

In addition to all the features of the smaller 2361 series valves, large size Mueller 2361 series RW valves offer these features:

- STEM – 18"-54" manganese bronze casting with integral thrust collar.



SIZE	AWWA C515 WORKING PRESSURE	UL WORKING PRESSURE	FM WORKING PRESSURE
14"-16"	250	250	250
18"-24"	250	175*	-
30"-48"	250	-	-
54"	250†	-	-

† AWWA C515 does not recognise valves larger than 48"

\* UL Listed without gearing

Certified to NSF 61 & 372

**MUELLER 2361 SERIES RESILIENT WEDGE GATE VALVES WITH AQUAGRIP<sup>®</sup> SYSTEM**

The Mueller AquaGrip System is offered in 4" through 12" sizes of the Mueller 2361 Series Resilient Wedge Gate Valves. This Mueller exclusive combines both the compression connection and the pipe restraint system in one convenient, quick installation package. This eliminates the need for anchor couplings, tie rods or separate gland-type restrains. A typical AquaGrip connection uses fewer bolts than a conventional mechanical joint end, and substantially fewer than a gland-type restraint, significantly reducing installation time. This "labor saving" system is also available on Mueller Centurion<sup>®</sup> Fire Hydrants, and as separate couplings and fittings to compliment water main installation needs.

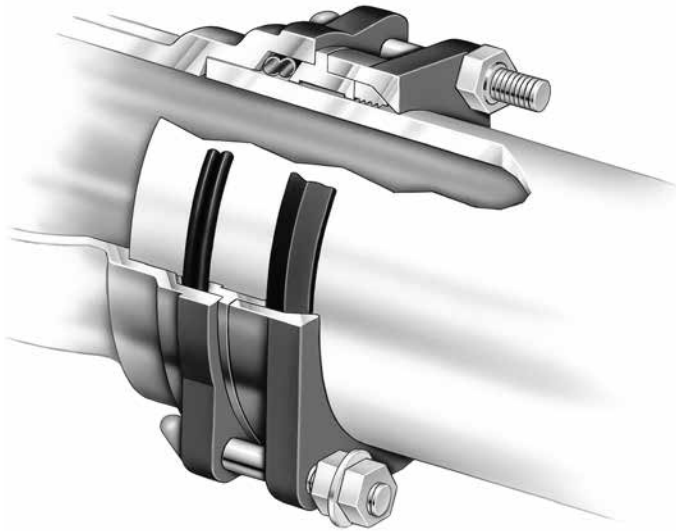

- ❑ ACCEPTS VARIED TYPES OF PIPE – DIPS style fits DI, C900 PVC and DIPS PE pipe. IPS style fits PVC, IPS PE. No disassembly or adapters, no special pipe end preparation, a liner for PE pipe(DR9-DR17) is recommended.
- ❑ FULLY ASSEMBLED STAB CONNECTION – arrives ready to insert the pipe, tighten the bolts and it's done. No need to change-out, add or remove parts. Nothing additional to inventory or handle in the field. No extra bolts to assemble or tighten. Substantially reduces labor and inventory costs.
- ❑ VISUALLY SHOWS WHEN PROPERLY TIGHTENED – breakaway nuts snap off using a standard wrench. No special torque requirements. Inner nut remains in place to allow future access to connection, if required. Reduces crew training and saves installation time. (In illustration, lower nut shown before tightening, upper one after.)
- ❑ CERTIFIED TO ANSI/NSF 61 – manufactured and tested in compliance with ANSI/AWWA C515. UL 262 Listed and FM 1120/1130 approved.
- ❑ PRESSURE RESPONSIVE O-RING SEAL – a double O-ring uses hydrostatic pressure from inside the pipe to enhance the seal as line pressure increases.
- ❑ FULL CIRCUMFERENTIAL RESTRAINT – gripper ring encircles pipe for uniform grip without creating points of high stress in pipe wall that could contribute to pipe failure.
- ❑ INSTALLS IN WET CONDITIONS – no special field conditions required, even installs under water.
- ❑ DUCTILE IRON CONSTRUCTION – valve body, bonnet and the Aqua-Grip System components.
- ❑ PLUS ALL THE OTHER FEATURES OF THE 2300 SERIES VALVES
- ❑ 250 PSIG MAX WORKING PRESSURE



**Reliable Connections™**

[www.muellercompany.com](http://www.muellercompany.com)  
[moreinfo@muellercompany.com](mailto:moreinfo@muellercompany.com)

---

Rev. 7-16 Shaded area indicates changes

- Catalog number–
  - A-2361-20** Mechanical joint ends (with accessories unassembled)
  - A-2361-23** Mechanical joint ends (less accessories)
  - A-2361-25** Mechanical joint ends (with transition gaskets accessories unassembled)
- Sizes – 4", 6", 8", 10", 12"
- Meets or exceeds all applicable requirements of ANSI/AWWA C515 Standard, UL 262 Listed, FM 1120/1130 Approved, and certified to ANSI/NSF 61 & 372
- Standard mechanical joint ends comply with ANSI/AWWA C111
- Iron body with nominal 10 mils MUELLER® Pro-Gard® Fusion Bonded Epoxy Coated interior and exterior surfaces
- Epoxy coating meets or exceeds all applicable requirements of ANSI/AWWA C550 Standard
- Iron wedge, symmetrical and fully encapsulated with molded rubber; no exposed iron
- Non-rising stem (NRS)
- Triple O-ring seal (2 above the thrust collar and 1 below)
- 2" square wrench nut - open left or open right
- 350 psig (2400 kPa/24 barg) maximum working pressure; 700 psig (4800 kPa/48 barg) static test pressure
- UL Listed, FM Approved: 350 psig (2400 kPa/24 barg)
- Mueller valves are designed for potable water applications

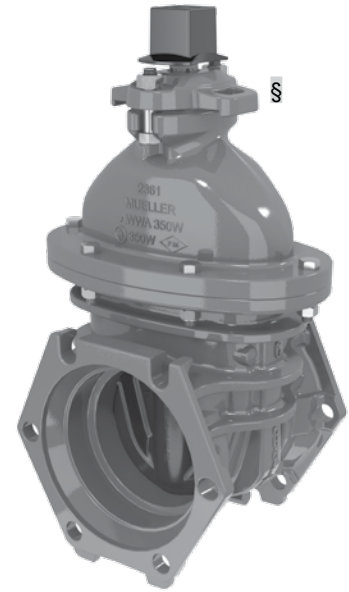

**A-2361-20**

### Options

See page 10.46 for more information on Resilient Wedge Gate Valve options

- Position indicators
- Stainless steel fasteners: Type 316
- Stainless steel stem: Type 304, Type 316
- ASTM B98-C66100/H02 stem
- Handwheel
- EPDM Disc and o-rings

### Resilient wedge gate valve parts

Catalog Part No.	Description	Material	Material Standard
G-16	Bonnet Bolts & Nuts	304 Stainless Steel	ASTM F593 (bolt) ASTM F594 (nut)
G-41	Stuffing Box Bolts & Nuts	304 Stainless Steel	ASTM F593 (bolt) ASTM F594 (nut)
G-49	Stem O-rings (3)	Nitrile	ASTM D2000
G-200	Wrench Nut Cap Screw	304 Stainless Steel	ASTM F593
G-201	Stuffing Box O-ring	Nitrile	ASTM D2000
G-202	Wrench Nut	Ductile Iron	ASTMA536 ▼
G-203	Stem	Bronze	ASTM B138
G-204	Hand Wheel (not shown)	Cast Iron +	ASTMA126 CL.B
G-205	Stem Nut	Bronze	ASTM B584
G-206	Guide Cap Bearings	Acetal	-
G-207	Stuffing Box with dirt seal	Ductile Iron Nitrile	ASTMA536 ▼ ASTM D2000
G-208	Anti-friction Washers (2)	Acetal	-
G-209	Wedge, Rubber Encapsulation	Ductile Iron* SBR	ASTMA536 ▼ ASTM D2000
G-210**	Bonnet	Ductile Iron	ASTMA536 ▼
G-211**	Bonnet gasket	Nitrile	ASTM D2000
G-212**	Body	Ductile Iron	ASTMA536 ▼

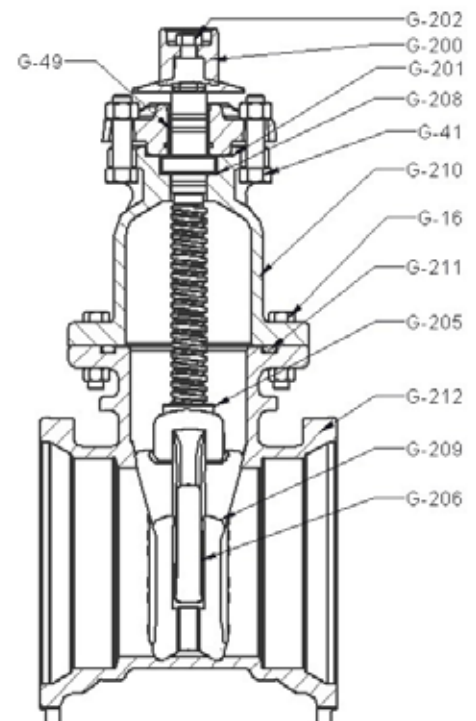

\*Fully encapsulated in molded rubber with no iron exposed

▼ Material strength ASTM A536 65-45 minimum

+ Manufacturer's option to upgrade material to ductile iron ASTM A536

**4" - 12" A-2361 RESILIENT WEDGE  
GATE VALVES - M.J. x M.J.**



**10.5**

Shaded area indicates change Rev. 7-16

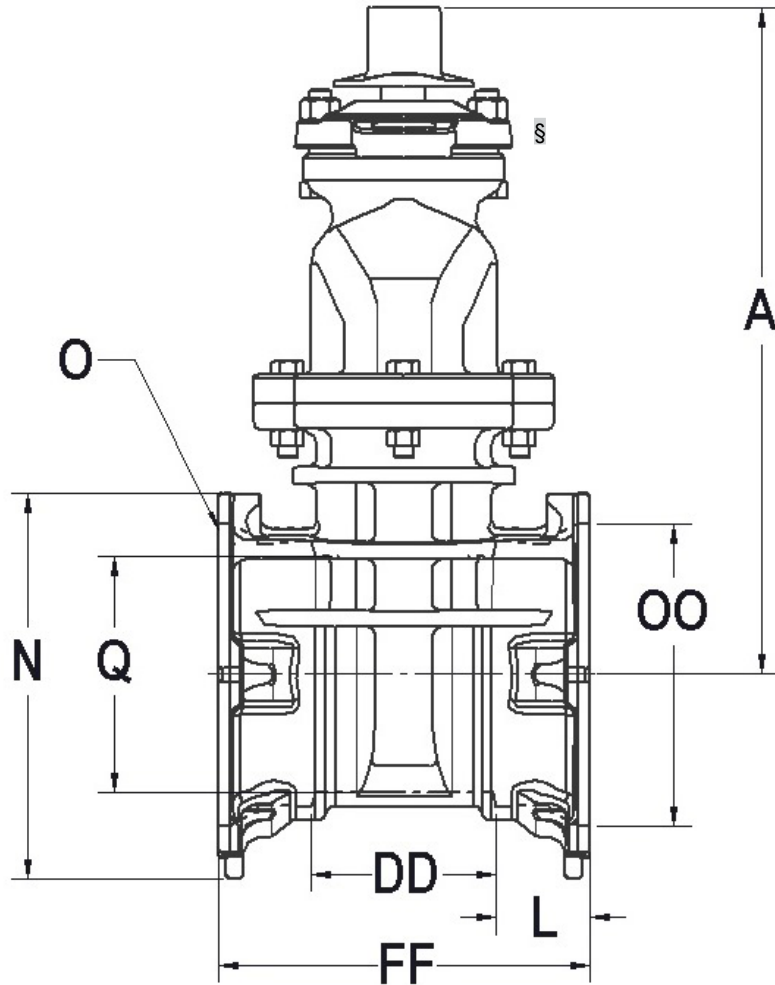

**Dimensions**

Dimension	Nominal Size				
	4"	6"	8"	10"	12"
A	14.19	18.00	21.50	25.50	28.62
FF	9.50	10.00	10.50	11.50	12.00
L	2.50	2.50	2.50	2.50	2.50
N	8.40	10.41	12.68	15.24	18.024
O (number and size of holes)	4--.88	6--.88	6--.88	8--.88	8--.88
DD	4.50	5.00	5.50	6.50	7.00
Q	4.30	6.30	8.30	10.30	12.30
OO (bolt circle diameter)	7.50	9.50	11.75	14.00	16.25
Turns to open	14	20.5	26.5	33.0	38.5
Weight*	70	112	162	238	303

\*All dimensions are in inches. All weights include accessories are in pounds and are approximate.

Rev. 7-16 Shaded area indicates changes

- Catalog number – **A-2361-6** flanged ends
- Sizes – 4", 6", 8", 10", 12"
- Meets or exceeds all applicable requirements of ANSI/AWWA C515 Standard, UL 262 Listed, FM 1120/1130 Approved, and certified to ANSI/NSF 61 & 372
- Flanged end drilling complies with ASME/ANSI B16.1 Class 125\*\*
- Iron body with nominal 10 mils MUELLER® Pro-Guard® Fusion Bonded Epoxy Coated interior and exterior surfaces
- Epoxy coating meets or exceeds all applicable requirements of ANSI/AWWA C550 Standard
- Iron wedge, symmetrical and fully encapsulated with molded rubber; no exposed iron
- Non-rising stem (NRS)
- Triple O-ring seal (2 above the thrust collar and 1 below)
- 2" square wrench nut - open left or open right
- 350 psig (2400 kPa/24 barg) maximum working pressure; 700 psig (4800 kPa/48 barg) static test pressure
- UL Listed, FM Approved: 350 psig (2400 kPa/24 barg)
- Mueller valves are designed for potable water applications

† Approved for backflow prevention devices by USC (for 4" - 10" sizes)



**A-2361-6**

### Options

See page 10.46 for more information on Resilient Wedge Gate Valve options

- Position indicators
- Stainless steel fasteners: Type 316
- Stainless steel stem: Type 304, Type 316
- 2" square wrench nut
- P/N 10/16 Drilling
- EPDM Disc and O-rings
- ASTM B98-C66100/H02 stem

### Resilient wedge gate valve parts

Catalog Part No.	Description	Material	Material Standard
G-16	Bonnet Bolts & Nuts	304 Stainless Steel	ASTM F593 (bolt) ASTM F594 (nut)
G-41	Stuffing Box Bolts & Nuts	304 Stainless Steel	ASTM F593 (bolt) ASTM F594 (nut)
G-49	Stem O-rings (3)	Nitrile	ASTM D2000
G-200	Wrench Nut Cap Screw	304 Stainless Steel	ASTM F593
G-201	Stuffing Box O-ring	Nitrile	ASTM D2000
G-202	Wrench Nut	Ductile Iron	ASTMA536 ▼
G-203	Stem	Bronze	ASTM B138
G-204	Hand Wheel	Cast Iron +	ASTM A126 CL.B
G-205	Stem Nut	Bronze	ASTM B584
G-206	Guide Cap Bearings	Acetal	-
G-207	Stuffing Box with dirt seal	Ductile Iron Nitrile	ASTM A536 ▼ ASTM D2000
G-208	Anti-friction Washers (2)	Acetal	-
G-209	Wedge, Rubber Encapsulation	Ductile Iron* SBR	ASTM A536 ▼ ASTM D2000
G-210	Bonnet	Ductile Iron	ASTMA536 ▼
G-211	Bonnet gasket	Nitrile	ASTM D2000
G-212	Body	Ductile Iron	ASTMA536 ▼

\*Fully encapsulated in molded rubber with no iron exposed

▼ Material strength ASTM A536 65-45 minimum

\*\* Per ANSI/AWWA C111, working pressure above 250psi requires the use of a special gasket rated for the higher pressure.

+ Manufacturer's option to upgrade material to ductile iron ASTM A536

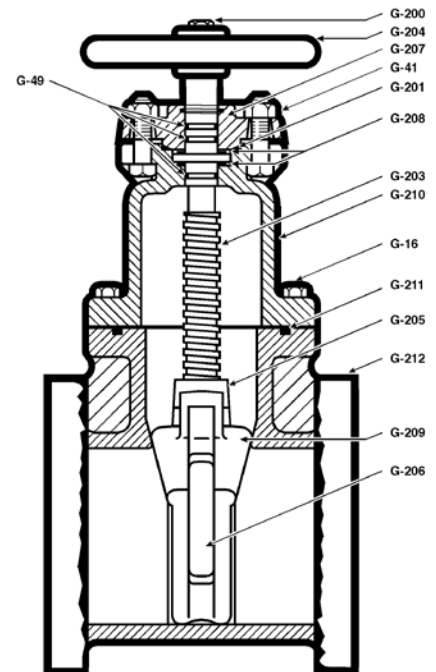

# 4" - 12" A-2361 RESILIENT WEDGE GATE VALVES - FL. x FL.



# 10.7

Shaded area indicates change Rev. 7-16

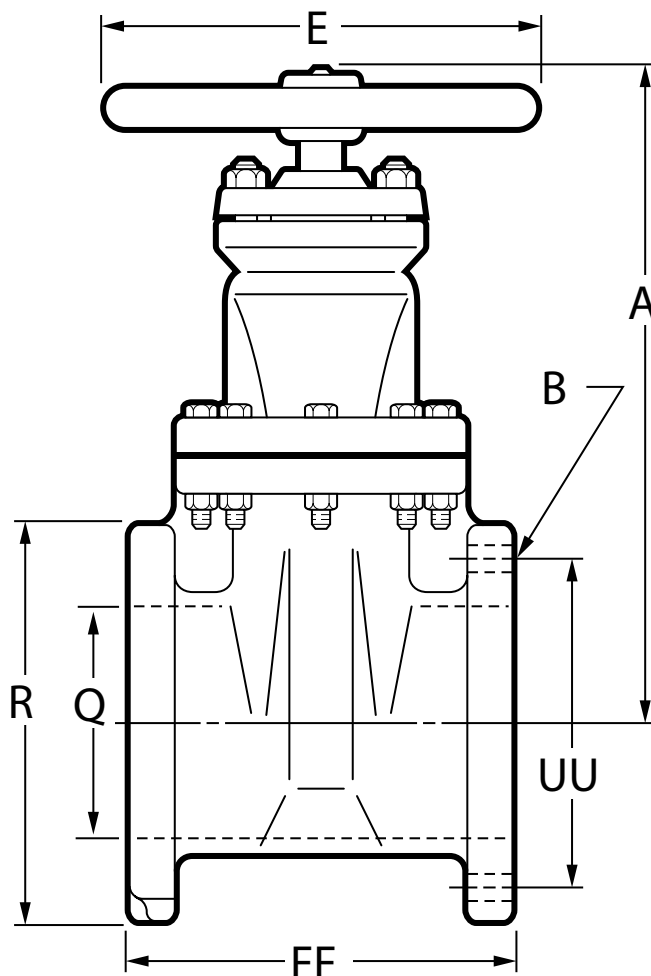

## Dimensions

Dimension	Nominal Size				
	4"	6"	8"	10"	12"
A	14.19	18.00	21.50	25.50	28.62
E	11.00	13.00	14.00	16.00	16.00
R	9.00	11.00	13.50	16.00	19.00
FF	9.00	10.50	11.50	13.00	14.00
Q (bore)	4.30	6.30	8.30	10.30	12.30
UU (bolt circle diameter)	7.50	9.50	11.75	14.25	17.00
B (number and size of holes)	8--.75	8--.88	8--.88	12--1.00	12--1.00
Turns to open	14	20.5	26.5	33	38.5
Weight*	81	136	213	326	440

\*All dimensions are in inches. All weights are in pounds and are approximate.

Rev. 7-16 Shaded area indicates changes

- Catalog number –
  - A-2361-16** mechanical joint x flanged ends (with accessories unassembled)
  - A-2361-19** mechanical joint x flanged ends (less accessories)
- Sizes – 4", 6", 8", 10", 12"
- Meets or exceeds all applicable requirements of ANSI/AWWA C515 Standard, UL 262 Listed, FM 1120/130 Approved, and certified to ANSI/NSF 61 & 372
- Flanged end drilling complies with ASME/ANSI B16.1 Class 125\*\*
- Mechanical joint end complies with ANSI/AWWA C111 Standard
- Iron body with nominal 10 mils MUELLER® Pro-Guard® Fusion Bonded Epoxy Coated interior and exterior surfaces
- Epoxy coating meets or exceeds all applicable requirements of ANSI/AWWA C550 Standard
- Iron wedge, symmetrical and fully encapsulated with molded rubber; no exposed iron
- Non-rising stem (NRS)
- Triple O-ring seal (2 above the thrust collar and 1 below)
- 2" square wrench nut - open left or open right
- 350 psig (2400 kPa/24 barg) maximum working pressure; 700 psig (4800 kPa/48 barg) static test pressure
- UL Listed, FM Approved – 350 psig (2400 kPa/24 barg)
- Mueller valves are designed for potable water applications



**A-2361-16**  
M.J. accessories  
shipped unassembled

### Options

See page 10.46 for more information on Resilient Wedge Gate Valve options

- Position indicators
- ASTM B98-C66100/H02 stem
- Stainless steel stem: Type 304, Type 316
- Handwheel
- EPDM Disc and o-rings
- Stainless steel fasteners: Type 316

### Resilient wedge gate valve parts

Catalog Part No.	Description	Material	Material Standard
G-16	Bonnet Bolts & Nuts	304 Stainless Steel	ASTM F593 (bolt) ASTM F594 (nut)
G-41	Stuffing Box Bolts & Nuts	304 Stainless Steel	ASTM F593 (bolt) ASTM F594 (nut)
G-49	Stem O-rings (3)	Nitrile	ASTM D2000
G-200	Wrench Nut Cap Screw	304 Stainless Steel	ASTM F593
G-201	Stuffing Box O-ring	Nitrile	ASTM D2000
G-202	Wrench Nut	Ductile Iron	ASTMA536 ▼
G-203	Stem	Bronze	ASTM B138
G-204	Hand Wheel (not shown)	Cast Iron +	ASTM A126 CL.B
G-205	Stem Nut	Bronze	ASTM B584
G-206	Guide Cap Bearings	Acetal	-
G-207	Stuffing Box with dirt seal	Ductile Iron Nitrile	ASTM A536 ▼ ASTM D2000
G-208	Anti-friction Washers (2)	Acetal	-
G-209	Wedge, Rubber Encapsulation	Ductile Iron* SBR	ASTMA536 ▼ ASTM D2000
G-210	Bonnet	Ductile Iron	ASTMA536 ▼
G-211	Bonnet gasket	Nitrile	ASTM D2000
G-212	Body	Ductile Iron	ASTMA536 ▼

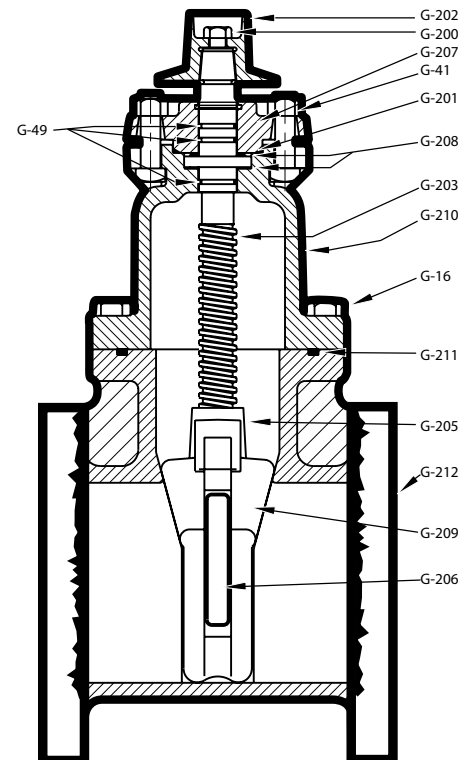

\*Fully encapsulated in molded rubber with no iron exposed

▼ Material strength ASTM A536 65-45 minimum

\*\* Per ANSI/AWWA C111, working pressure above 250psi requires the use of a special gasket rated for the higher pressure.

+ Manufacturer's option to upgrade material to ductile iron ASTM A536



# 4" - 12" A-2361 RESILIENT WEDGE GATE VALVES - M.J. x FL.



# 10.9

Shaded area indicates change Rev. 7-16

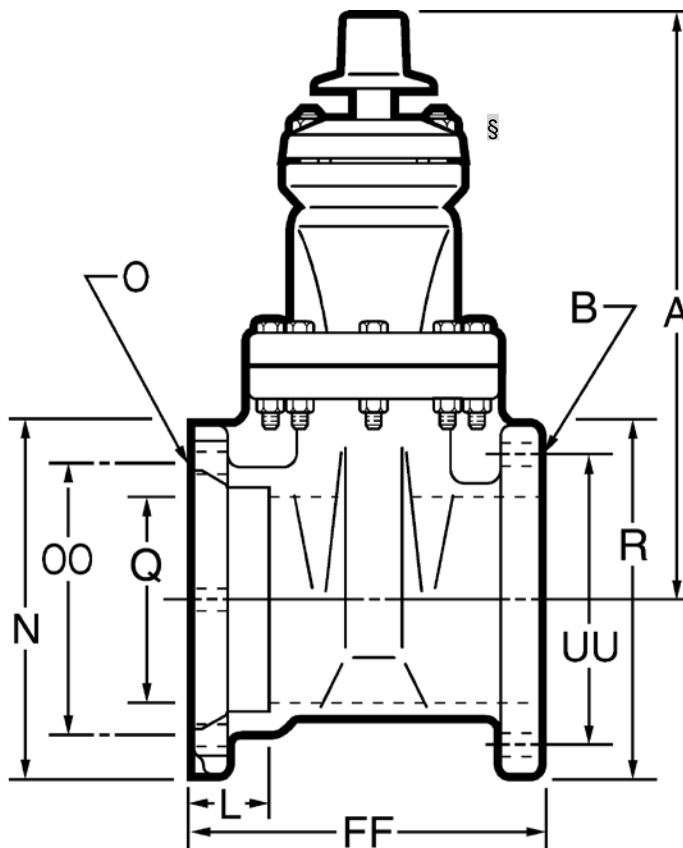

## Dimensions

Dimension	Nominal Size				
	4"	6"	8"	10"	12"
A	14.19	18.00	21.50	25.50	28.62
L	2.50	2.50	2.50	2.50	2.50
N	9.12	11.12	13.37	15.62	17.88
O	4--.88	6--.88	6--.88	8--.88	8--.88
Q (bore)	4.30	6.30	8.30	10.30	12.30
OO (bolt circle diameter)	7.50	9.50	11.75	14.00	16.25
R (number and size of holes)	9.00	11.00	13.50	16.00	19.00
UU	7.50	9.50	11.75	14.25	17.00
FF	9.50	11.06	12.09	13.94	14.50
B	8--.75	8--.88	8--.88	12--1.00	12--1.00
Turns to open	14	20.5	26.5	33	38.5
Weight*	110	156	256	368	528

\* All dimensions are in inches. All weights include accessories are in pounds and are approximate.

Rev. 7-16 Shaded area indicates changes

- Catalog number–  
**A-2361-38** Slip-on† ends with gasket  
**A-2361-40** Slip-on† ends less gasket
- Sizes – 4", 6", 8", 10", 12"
- Meets or exceeds all applicable requirements of ANSI/AWWA C515 Standard, UL 262 Listed, FM 1120/1130 Approved, and certified to ANSI/NSF 61 & 372
- Slip-on ends fit plain end of classes 150, 200 and 250 cast iron; ductile iron and classes 150 and 200 cast iron O.D. PVC
- Iron body with nominal 10 mils MUELLER® Pro-Gard® Fusion Bonded Epoxy Coated interior and exterior surfaces
- Epoxy coating meets or exceeds all applicable requirements of ANSI/AWWA C550 Standard
- Iron wedge, symmetrical and fully encapsulated with molded rubber; no exposed iron
- Non-rising stem (NRS)
- Triple O-ring seal (2 above the thrust collar and 1 below)
- 2" square wrench nut - open left or open right
- 350 psig (2400 kPa/24 barg) maximum working pressure; 700 psig (4800 kPa/48 barg) static test pressure
- UL Listed, FM Approved: 350 psig (2400 kPa/24 barg)
- Mueller valves are designed for potable water applications



**A-2361-38**

*Slip-on ends on this valve are not intended for use with Field Lok†† restrained gaskets. Use valve on page 10.13A*

†Design and dimensions of the joint are manufactured under license of U.S. Pipe and Foundry Company.

††Field Lok is a trademark of U.S. Pipe and Foundry Company, used with permission.

### Options

See page 10.46 for more information on Resilient Wedge Gate Valve options

- Position indicators
- Stainless steel fasteners: Type 316
- Stainless steel stem: Type 304, Type 316
- ASTM B98-C66100/H02 stem
- Handwheel
- EPDM Disc and o-rings

### Resilient wedge gate valve parts

Catalog Part No.	Description	Material	Material Standard
G-16	Bonnet Bolts & Nuts	304 Stainless Steel	ASTM F593 (bolt) ASTM F594 (nut)
G-41	Stuffing Box Bolts & Nuts	304 Stainless Steel	ASTM F593 (bolt) ASTM F594 (nut)
G-49	Stem O-rings (3)	Nitrile	ASTM D2000
G-200	Wrench Nut Cap Screw	304 Stainless Steel	ASTM F593
G-201	Stuffing Box O-ring	Nitrile	ASTM D2000
G-202	Wrench Nut	Ductile Iron	ASTMA536 ▼
G-203	Stem	Bronze	ASTM B138
G-204	Hand Wheel (not shown)	Cast Iron +	ASTM A126 CL.B
G-205	Stem Nut	Bronze	ASTM B584
G-206	Guide Cap Bearings	Acetal	-
G-207	Stuffing Box with dirt seal	Ductile Iron Nitrile	ASTMA536 ▼ ASTM D2000
G-208	Anti-friction Washers (2)	Acetal	-
G-209	Wedge, Rubber Encapsulation	Ductile Iron SBR*	ASTMA536 ▼ ASTM D2000
G-210	Bonnet	Ductile Iron	ASTMA536 ▼
G-211	Bonnet O-ring	Nitrile	ASTM D2000
G-212	Body	Ductile Iron	ASTMA536 ▼

\*Fully encapsulated in molded rubber with no iron exposed

▼ Material strength ASTM A536 65-45 minimum

+ Manufacturer's option to upgrade material to ductile iron ASTM A536

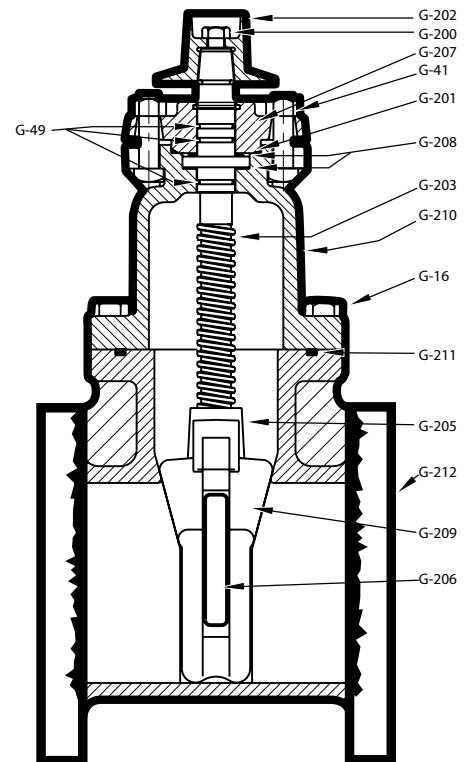

**4" - 12" A-2361 RESILIENT WEDGE  
GATE VALVES - SL. x SL.**



**10.11**

Shaded area indicates change Rev. 7-16

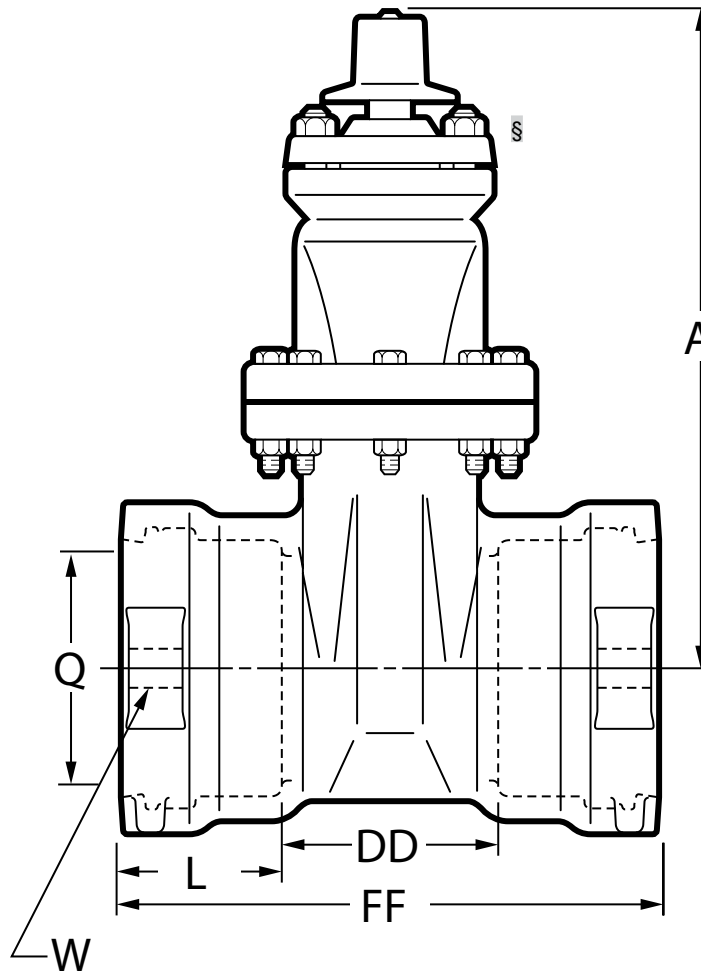

**Dimensions**

Dimension	Nominal Size				
	4"	6"	8"	10"	12"
A	14.19	18.00	21.50	25.50	28.62
Q (bore)	4.30	6.30	8.30	10.30	12.30
W (distance between strapping lug holes across face of valve ends)	8.62	10.62	13.12	16.38	18.12
FF	12.81	14.96	17.94	18.50	18.70
L	4.12	4.38	5.62	5.62	5.62
DD	4.57	6.20	6.70	7.26	7.46
Turns to open	14	20.5	26.5	33	38.5
Weight*	85	144	233	368	523

\*All dimensions are in inches. All weights are in pounds and are approximate.

Rev. 7-16 Shaded area indicates changes

- Catalog number–  
**A-2361-41** Slip-on† end (with gasket) x flange end  
**A-2361-43** Slip-on† end (less gasket) x flange end
- Sizes – 4", 6", 8", 10", 12"
- Meets or exceeds all applicable requirements of ANSI/AWWA C515 Standard, UL 262 Listed, FM 1120/1130 Approved, and certified to ANSI/NSF 61 & 372
- Slip-on ends fit plain end of classes 150, 200 and 250 cast iron, ductile iron and classes 150 and 200 cast iron O.D. PVC
- Flange end drilling complies with ASME/ANSI B16.1 Class 125\*\*
- Iron body with nominal 10 mils MUELLER® Pro-Gard® Fusion Bonded Epoxy Coated interior and exterior surfaces
- Epoxy coating meets or exceeds all applicable requirements of ANSI/AWWA C550 Standard
- Iron wedge, symmetrical and fully encapsulated with molded rubber; no exposed iron
- Non-rising stem (NRS)
- Triple O-ring seal (2 above the thrust collar and 1 below)
- 2" square wrench nut - open left or open right
- 350 psig (2400 kPa/24 barg) maximum working pressure; 700 psig (4800 kPa/48 barg) static test pressure
- UL Listed, FM Approved: 350 psig (2400 kPa/24 barg)
- Mueller valves are designed for potable water applications



**A-2361-41**

*Slip-on end on this valve is not intended for use with Field Lok†† restrained gaskets. Use valve on page 10.13C*

†Design and dimensions of the joint are manufactured under license of U.S. Pipe and Foundry Company.  
 ††Field Lok is a trademark of U.S. Pipe and Foundry Company, used with permission.

### Options

See page 10.46 for more information on Resilient Wedge Gate Valve options

- Position indicators
- Stainless steel fasteners: Type 316
- Stainless steel stem: Type 304, Type 316
- ASTM B98-C66100/H02 stem
- Handwheel
- EPDM Disc and o-rings

### Resilient wedge gate valve parts

Catalog Part No.	Description	Material	Material Standard
G-16	Bonnet Bolts & Nuts	304 Stainless Steel	ASTM F593 (bolt) ASTM F594 (nut)
G-41	Stuffing Box Bolts & Nuts	304 Stainless Steel	ASTM F593 (bolt) ASTM F594 (nut)
G-49	Stem O-rings (3)	Nitrile	ASTM D2000
G-200	Wrench Nut Cap Screw	304 Stainless Steel	ASTM F593
G-201	Stuffing Box O-ring	Nitrile	ASTM D2000
G-202	Wrench Nut	Ductile Iron	ASTMA536 ▼
G-203	Stem	Bronze	ASTM B138
G-204	Hand Wheel (not shown)	Cast Iron +	ASTM A126 CL.B
G-205	Stem Nut	Bronze	ASTM B584
G-206	Guide Cap Bearings	Acetal	-
G-207	Stuffing Box with dirt seal	Ductile Iron Nitrile	ASTM A536 ▼ ASTM D2000
G-208	Anti-friction Washers (2)	Acetal	-
G-209	Wedge, Rubber Encapsulation	Ductile Iron* SBR	ASTMA536 ▼ ASTM D2000
G-210	Bonnet	Ductile Iron	ASTMA536 ▼
G-211	Bonnet O-ring	Nitrile	ASTM D2000
G-212	Body	Ductile Iron	ASTMA536 ▼

\*Fully encapsulated in molded rubber with no iron exposed

▼ Material strength ASTM A536 65-45 minimum

\*\* Per ANSI/AWWA C111, working pressure above 250psi requires the use of a special gasket rated for the higher pressure.

+ Manufacturer's option to upgrade material to ductile iron ASTM A536

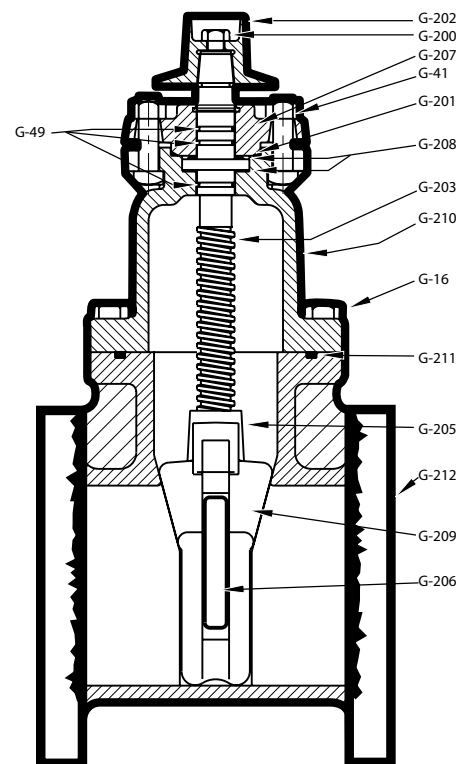

# 4" - 12" A-2361 RESILIENT WEDGE GATE VALVES - SL. x FL.



# 10.13

Shaded area indicates change Rev. 7-16

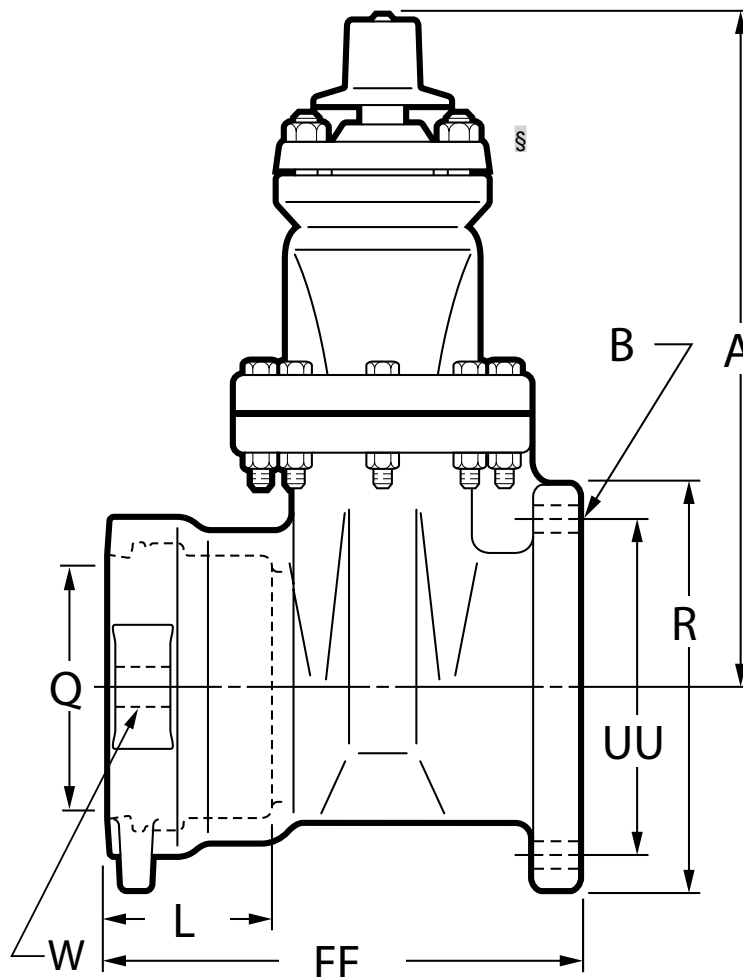

## Dimensions

Dimension	Nominal Size				
	4"	6"	8"	10"	12"
A	14.19	18.00	21.50	25.50	28.62
Q (bore)	4.30	6.30	8.30	10.30	12.30
L	4.12	4.38	5.62	5.62	5.62
R	9.00	11.00	13.50	16.00	19.00
UU (bolt circle diameter for FL)	7.50	9.50	11.75	14.25	17.00
B (number and size of holes for FL)	8--.75	8--.88	8--.88	12--1.00	12--1.00
W (distance between strapping lug holes across face of valve ends)	8.62	10.62	13.12	16.38	18.12
FF	10.91	12.73	14.72	15.75	16.35
Turns to open	14	20.5	26.5	33	38.5
Weight*	93	140	241	368	523

\*All dimensions are in inches. All weights are in pounds and are approximate.

Rev. 7-16 Shaded area indicates changes

- Catalog number–  
**A-2361-61** Slip On ends (less Field Lok gaskets)
- Sizes – 4", 6", 8", 12"
- Meets or exceeds all applicable requirements of ANSI/AWWA C515 Standard, UL 262 Listed, FM 1120/1130 Approved, and certified to ANSI/NSF 61 & 372
- Slip-on ends with Field Lok gaskets are to be used on ductile iron pipe
- Iron body with nominal 10 mils MUELLER® Pro-Gard® Fusion Bonded Epoxy Coated interior and exterior surfaces
- Epoxy coating meets or exceeds all applicable requirements of ANSI/AWWA C550 Standard
- Iron wedge, symmetrical and fully encapsulated with molded rubber; no exposed iron
- Non-rising stem (NRS)
- Triple O-ring seal (2 above the thrust collar and 1 below)
- 2" square wrench nut - open left or open right
- 350 psig (2400 kPa/24 barg) maximum working pressure; 700 psig (4800 kPa/48 barg) static test pressure
- UL Listed, FM Approved: 350 psig (2400 kPa/24 barg)
- Mueller valves are designed for potable water applications



**A-2361-61**

Slip-on ends on this valve are intended for use with Field Lok†† restrained gaskets.

†Design and dimensions of the joint are manufactured under license of U.S. Pipe and Foundry Company.

††Field Lok is a trademark of U.S. Pipe and Foundry Company, used with permission.

### Options

See page 10.46 for more information on Resilient Wedge Gate Valve options

- Position indicators
- Stainless steel fasteners: Type 316
- Stainless steel stem: Type 304, Type 316
- ASTM B98-C66100/H02 stem
- Handwheel
- EPDM Disc and o-rings

### Resilient wedge gate valve parts

Catalog Part No.	Description	Material	Material Standard
G-16	Bonnet Bolts & Nuts	304 Stainless Steel	ASTM F593 (bolt) ASTM F594 (nut)
G-41	Stuffing Box Bolts & Nuts	304 Stainless Steel	ASTM F593 (bolt) ASTM F594 (nut)
G-49	Stem O-rings (3)	Nitrile	ASTM D2000
G-200	Wrench Nut Cap Screw	304 Stainless Steel	ASTM F593
G-201	Stuffing Box O-ring	Nitrile	ASTM D2000
G-202	Wrench Nut	Ductile Iron	ASTMA536 ▼
G-203	Stem	Bronze	ASTM B138
G-204	Hand Wheel (not shown)	Cast Iron +	ASTMA126 CL.B
G-205	Stem Nut	Bronze	ASTM B584
G-206	Guide Cap Bearings	Acetal	-
G-207	Stuffing Box with dirt seal	Ductile Iron Nitrile	ASTMA536 ▼ ASTM D2000
G-208	Anti-friction Washers (2)	Acetal	-
G-209	Wedge, Rubber Encapsulation	Ductile Iron* SBR	ASTMA536 ▼ ASTM D2000
G-210	Bonnet	Ductile Iron	ASTMA536 ▼
G-211	Bonnet O-ring	Nitrile	ASTM D2000
G-212	Body	Ductile Iron	ASTMA536 ▼

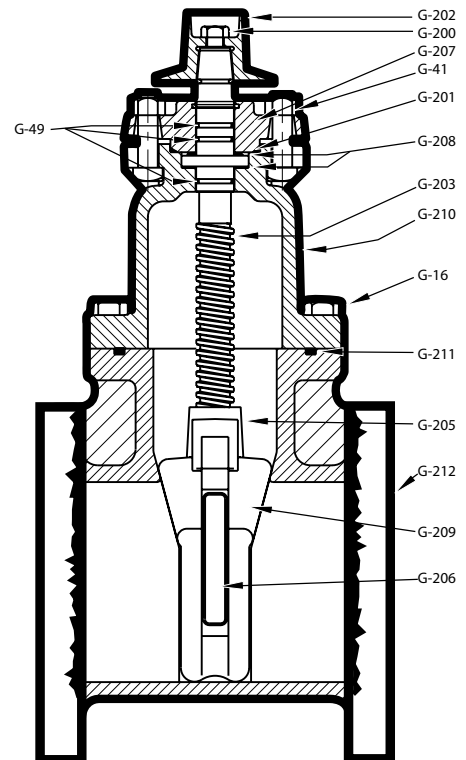

\*Fully encapsulated in molded rubber with no iron exposed

▼ Material strength ASTM A536 65-45 minimum

+ Manufacturer's option to upgrade material to ductile iron ASTM A536

**4" - 12" A-2361 RESILIENT WEDGE GATE  
VALVES - SL x SL. (FOR FIELD LOK™\*\* GASKETS)**



**10.13B**

Shaded area indicates change Rev. 7-16

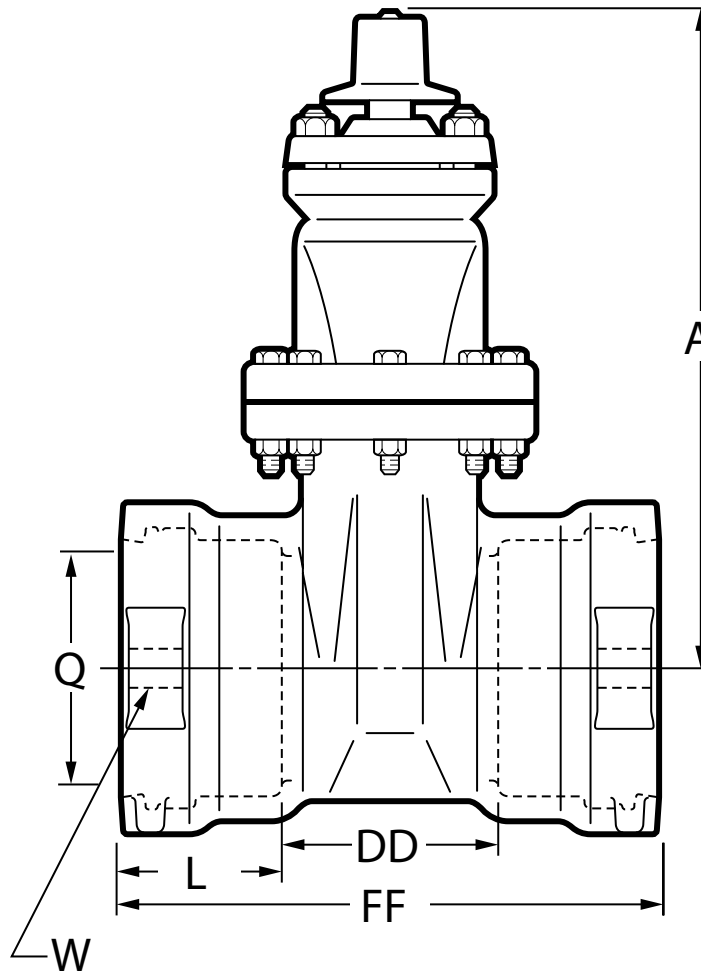

**Dimensions**

Dimension	Nominal Size				
	4"	6"	8"	10"	12"
A	14.19	18.00	21.50	25.50	28.62
Q (bore)	4.30	6.30	8.30	10.30	12.30
W (distance between strapping lug holes across face of valve ends)	8.62	10.62	13.12	16.38	18.12
FF	12.81	14.96	17.94	18.50	18.70
L	4.12	4.38	5.62	5.62	5.62
DD	4.57	6.2	6.7	7.26	7.46
Turns to open	14	20.5	26.5	33	38.5
Weight*	85	144	233	368	523

\*All dimensions are in inches. All weights are in pounds and are approximate.

\*\*Field Lok is a trademark of U.S. Pipe and Foundry Company, used with permission.

Rev. 7-16 Shaded area indicates changes

- Catalog number–  
**A-2361-62** Slip On (less Field Lok gasket) x flange end
- Sizes – 4", 6", 8", 12"
- Meets or exceeds all applicable requirements of ANSI/AWWA C515 Standard, UL 262 Listed, FM 1120/1130 Approved, and certified to ANSI/NSF 61 & 372
- Slip-on ends with Field Lok gaskets are to be used on ductile iron pipe
- Flange end drilling complies with ASME/ANSI B16.1 Class 125\*\*
- Iron body with nominal 10 mils MUELLER® Pro-Gard® Epoxy Fusion Bonded Epoxy Coated interior and exterior surfaces
- Epoxy coating meets or exceeds all applicable requirements of ANSI/AWWA C550 Standard
- Iron wedge, symmetrical and fully encapsulated with molded rubber; no exposed iron
- Non-rising stem (NRS)
- Triple O-ring seal (2 above the thrust collar and 1 below)
- 2" square wrench nut - open left or open right
- 350 psig (2400 kPa/24 barg) maximum working pressure; 700 psig (4800 kPa/48 barg) static test pressure
- UL Listed, FM Approved: 350 psig (2400 kPa/24 barg)
- Mueller valves are designed for potable water applications



**A-2361-62**

Slip-on end on this valve is intended for use with Field Lok†† restrained gaskets.

†Design and dimensions of the joint are manufactured under license of U.S. Pipe and Foundry Company.  
††Field Lok is a trademark of U.S. Pipe and Foundry Company, used with permission.

### Options

See page 10.46 for more information on Resilient Wedge Gate Valve options

- Position indicators
- Stainless steel fasteners: Type 316
- Stainless steel stem: Type 304, Type 316
- ASTM B98-C66100/H02 stem
- Handwheel
- EPDM Disc and o-rings

### Resilient wedge gate valve parts

Catalog Part No.	Description	Material	Material Standard
G-16	Bonnet Bolts & Nuts	304 Stainless Steel	ASTM F593 (bolt) ASTM F594 (nut)
G-41	Stuffing Box Bolts & Nuts	304 Stainless Steel	ASTM F593 (bolt) ASTM F594 (nut)
G-49	Stem O-rings (3)	Nitrile	ASTM D2000
G-200	Wrench Nut Cap Screw	304 Stainless Steel	ASTM F593
G-201	Stuffing Box O-ring	Nitrile	ASTM D2000
G-202	Wrench Nut	Ductile Iron	ASTMA536 ▼
G-203	Stem	Bronze	ASTM B138
G-204	Hand Wheel (not shown)	Cast Iron +	ASTM A126 CL.B
G-205	Stem Nut	Bronze	ASTM B584
G-206	Guide Cap Bearings	Acetal	-
G-207	Stuffing Box with dirt seal	Ductile Iron Nitrile	ASTM A536 ▼ ASTM D2000
G-208	Anti-friction Washers (2)	Acetal	-
G-209	Wedge, Rubber Encapsulation	Ductile Iron* SBR	AASTMA536 ▼ ASTM D2000
G-210	Bonnet	Ductile Iron	ASTMA536 ▼
G-211	Bonnet O-ring	Nitrile	ASTM D2000
G-212	Body	Ductile Iron	ASTMA536 ▼

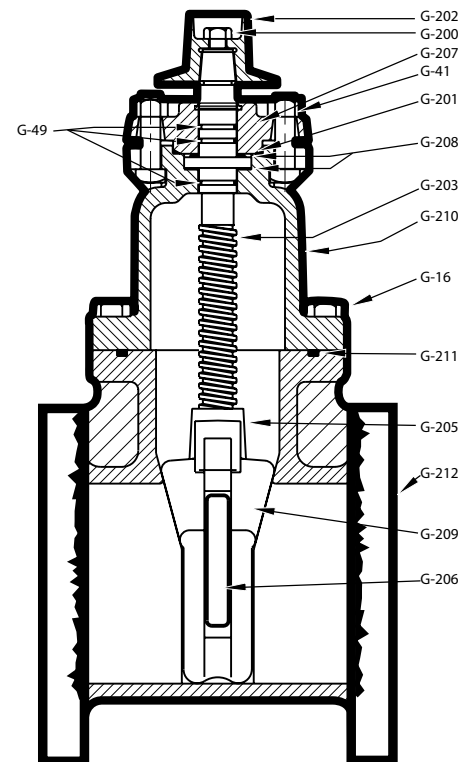

\*Fully encapsulated in molded rubber with no iron exposed

▼ Material strength ASTM A536 65-45 minimum

\*\* Per ANSI/AWWA C111, working pressure above 250psi requires the use of a special gasket rated for the higher pressure.

+ Manufacturer's option to upgrade material to ductile iron ASTM A536

**SEE PAGE 10.53 FOR ORDERING INSTRUCTIONS**



**4" - 12" A-2361 RESILIENT WEDGE GATE  
VALVES - SL x FL (FOR FIELD LOK™\*\* GASKETS)**



**10.13D**

Shaded area indicates change Rev. 7-16

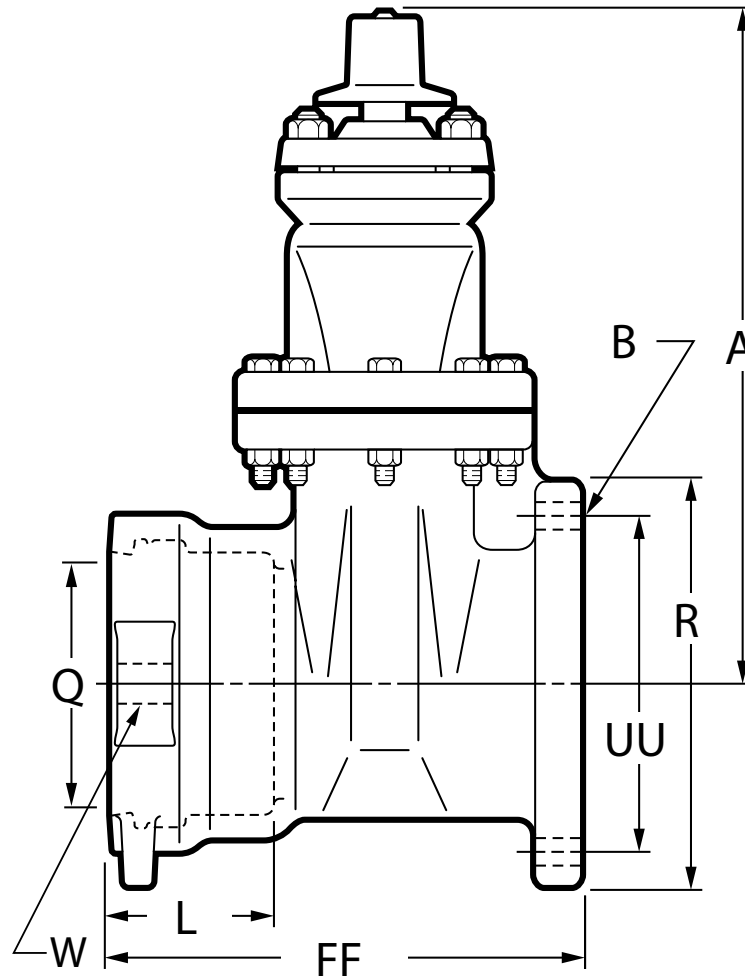

**Dimensions**

Dimension	Nominal Size				
	4"	6"	8"	10"	12"
A	14.19	18.00	21.50	25.50	28.62
Q (bore)	4.30	6.30	8.30	10.30	12.30
L	4.12	4.38	5.62	5.62	5.62
R	9.00	11.00	13.50	16.00	19.00
UU (bolt circle diameter for FL)	7.50	9.50	11.75	14.25	17.00
B (number and size of holes for FL)	8--.75	8--.88	8--.88	12--1.00	12--1.00
W (distance between strapping lug holes across face of valve ends)	8.62	10.62	13.12	16.38	18.12
FF	10.91	12.73	14.72	15.75	16.35
Turns to open	14	20.5	26.5	33	38.5
Weight*	93	140	241	368	523

\*All dimensions are in inches. All weights are in pounds and are approximate.

\*\*Field Lok is a trademark of U.S. Pipe and Foundry Company, used with permission.

Rev. 7-16 Shaded area indicates changes

- Catalog number– **A-2361-6** flanged ends
- Sizes – 14", 16", 18", 20", 24", 30", 36", 42", 48", 54"
- Meets or exceeds all applicable requirements of ANSI/AWWA C515 Standard (thru 48"), UL 262 Listed (thru 24"), FM 1120/1130 Approved (thru 16"), and certified to ANSI/NSF 61 & 372
- Flanged ends drilling comply with ASME/ANSI B16.1 Class 125
- Ductile iron body and bonnet with nominal 10 mils MUELLER® Pro-Gard® Fusion Bonded Epoxy Coated interior and exterior surfaces; 42" – 54" valves coated with Mueller HP Epoxy
- Epoxy coatings meet or exceed all applicable requirements of ANSI/AWWA C550 Standard
- Ductile iron wedge, symmetrical and fully encapsulated with molded rubber; no exposed iron.
- Non-rising stem (NRS)
- Triple O-ring seal (2 above the thrust collar and 1 below)
- 2" square wrench nut - open left or open right (30" - 54" require a Spur Gear or Bevel Gear)
- 250 psig (1725 kPa/17 barg) maximum working pressure; 500 psig (3450 kPa/35 barg) static test pressure
- 14" and 16" sizes – UL Listed, FM Approved: 250 psig (1725 kPa/17 barg)
- 18", 20" and 24" sizes – UL Listed (without gearing): 175 psig (1200 kPa/12 barg)
- Mueller valves are designed for potable water applications



**A-2361-6**

### Options

See page 27 for more information on Resilient Wedge Gate Valve options

- Stem Options:
  - 14"-16" Bronze ASTM B98-C66100/H02
  - Stainless Steel, Type 304, Type 316
  - 18"-54" Bronze ASTM B763-C99500
  - Stainless Steel Type 304, Type 316
- Stainless steel fasteners: Type 304, Type 316
- Position indicators
- Bypass 16"- 54" (2" on 16"-20"; 2.5" on 24"; 3" on 30"- 36", 4" on 42"-54")
- Handwheel
- Spur or bevel geared actuator
- EPDM Disc and o-rings, 14"-16" optional, 18"-54" standard

### Resilient wedge gate valve parts

Catalog Part No.	Description	Material	Material Standard
G-16	Bonnet Bolts & Nuts	Carbon Steel	SAE J429 (bolt) ASTM A563 (nut)
G-41	Stuffing Box Bolts & Nuts	Carbon Steel	SAE J429 (bolt) ASTM A563 (nut)
G-49	Stem O-rings (3)†	Nitrile	ASTM D2000
G-200	Wrench Nut Cap Screw	Carbon Steel	SAE J429
G-201	Stuffing Box O-ring†	Nitrile	ASTM D2000
G-202	Wrench Nut	Cast Iron+	ASTM A126 CL.B
G-203	Stem	Bronze	ASTM B138**
G-204	Hand Wheel (not shown)	Cast Iron+	ASTM A126 CL.B
G-205	Stem Nut	Bronze	ASTM B62
G-206	Guide Cap Bearings	Acetal	-
G-207	Stuffing Box	Ductile Iron++	ASTM A536 ▼
G-208	Anti-friction Washers (2)	Acetal	-
G-209	Wedge, Rubber Encapsulation	Ductile Iron* SBR†	ASTM A536 ▼ ASTM D2000
G-210	Bonnet	Ductile Iron	ASTM A536 ▼
G-211	Bonnet O-ring †	Nitrile	ASTM D2000
G-212	Body	Ductile Iron	ASTM A536 ▼

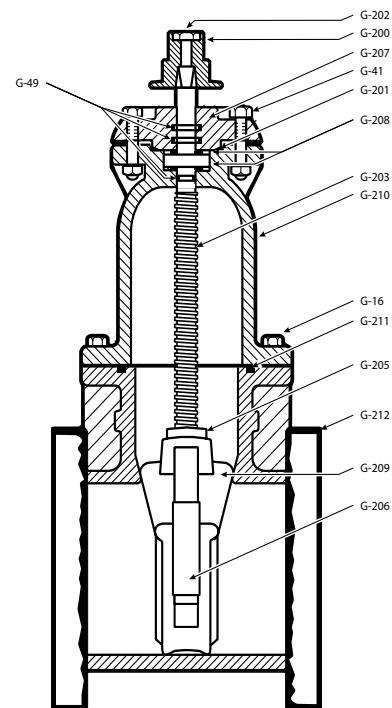

\* Fully encapsulated in molded rubber with no iron exposed

† 18"-54" EPDM standard

++ 30"-54" are hot rolled steel ASTM A36

\*\* 18"-54" ASTM B584

+ Manufacturers option to change material to Ductile iron ASTM A536

▼ Material strength ASTM A536 65-45 minimum

**14" - 54" A-2361 D.I. RESILIENT  
WEDGE GATE VALVES - FL. x FL.**



**10.15**

Shaded area indicates change Rev. 4-14

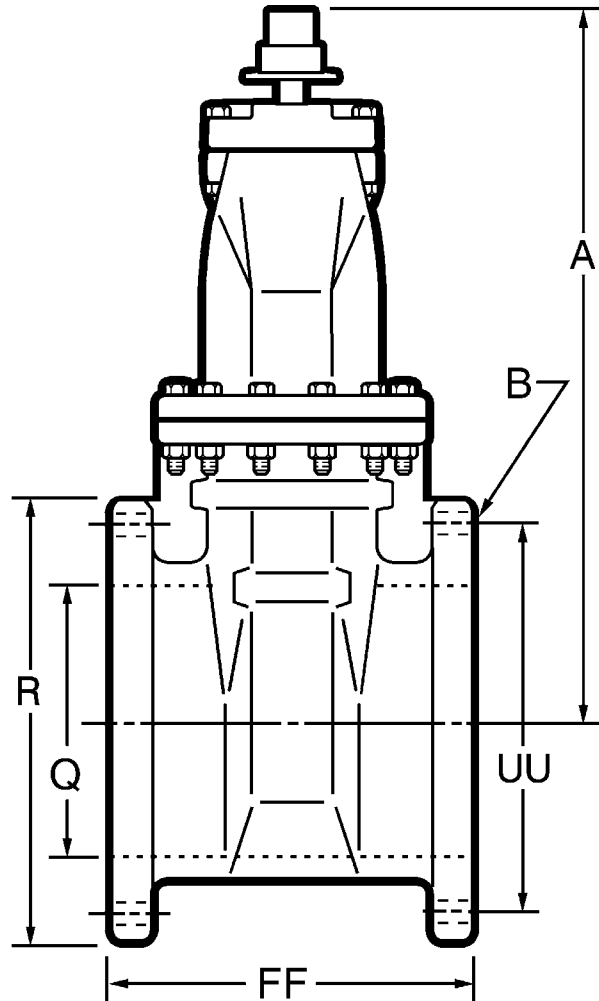

**Dimensions**

Dimension*	Nominal Size									
	14"	16"	18"	20"	24"	30" †	36" †	42" †	48" †	54" †
A	32.75	37.88	44.19	48.25	53.88	See A for Spur or Bevel Gear				
R	21.00	23.50	25.00	27.50	32.00	38.75	46.00	53.00	59.50	66.34
FF	15.06	16.06	17.00	18.00	20.00	26.00	30.00	38.00	43.00	48.00
Q (bore)	14.38	16.00	18.38	20.38	24.38	30.38	36.38	42.38	48.38	48.38
UU (bolt circle diameter)	18.75	21.25	22.75	25.00	29.50	36.00	42.75	49.50	56.00	62.76
B (number and size of holes)	12--1.125	16--1.125	16--1.25	20--1.25	20--1.38	28--1.38	32--1.63	36--1.63	44--1.63	44--2.00
A- Spur Gear	40.49	43.58	49.41	53.01	59.15	70.81	83.08	97.74	109.70	109.70
A - Bevel Gear**	34.55	37.77	44.50	47.69	54.06	64.93	77.19	90.75	102.61	102.61
Turns to open (without gearing)	43.5	49	57	63	75	-	-	-	-	-
Turns to open (Spur gearing)††	178	201	234	258	308	381	455	524	596	596
Turns to open (Bevel gearing)††	174	196	228	252	300	372	444	524	596	596
Weight*	690	859	1284	1774	2481	6390	8220	13400	19978	20900

\*All dimensions are in inches. All weights are in pounds and are approximate. Weights for 30"-54" valves are with gearing; for all others without gearing.

\*\*Center line of operating nut to center line of valve.

†Spur or Bevel Gear must be used with 30", 36", 42", 48" & 54" valves.

††Turns shown are for Rotoric gearing supplied by Mueller Co.

Rev. 7-16 Shaded area indicates changes

- Catalog number–  
**A-2361-16** mechanical joint x flanged ends (with accessories unassembled)  
**A-2361-19** mechanical joint x flanged ends (less accessories)
- Sizes – 14", 16", 18", 20", 24", 30", 36", 42", 48"
- Meets or exceeds all applicable requirements of ANSI/AWWA C515 Standard, UL 262 Listed, FM 1120/1130 Approved, and certified to ANSI/NSF 61 & 372
- Flanged end drilling complies with ASME/ANSI B16.1 Class 125
- Mechanical joint end complies with ANSI/AWWA C111 Standard
- Ductile iron body and bonnet with nominal 10 mils MUELLER® Pro-Gard® Fusion Bonded Epoxy Coated interior and exterior surfaces; 42" and 48" valves coated with Mueller HP Epoxy
- Epoxy coating meets or exceeds all applicable requirements of ANSI/AWWA C550 Standard
- Ductile iron wedge, symmetrical and fully encapsulated with molded rubber; no exposed iron.
- Non-rising stem (NRS)
- Triple O-ring seal (2 above the thrust collar and 1 below)
- 2" square wrench nut - open left or open right (30" - 48" require a Spur Gear or Bevel Gear)
- 250 psig (1725 kPa/17 barg) maximum working pressure; 500 psig (3450 kPa/35 barg) static test pressure
- 14" and 16" sizes – UL Listed, FM Approved: 250 psig (1725 kPa/17 barg)
- 18", 20" and 24" sizes – UL Listed: 175 psig (1200 kPa/12 barg)
- Mueller valves are designed for potable water applications



**A-2361-19**

### Options

See page 10.46 for more information on Resilient Wedge Gate Valve options

- ASTM B98-C66100/H02 stem: 14"-16", ASTM B763-C99500: 18"- 48"
- Stainless Steel Stem Type 304, Type 316: 14"- 48"
- Bypass 16" - 48" (2" on 16"-20"; 2.5" on 24"; 3" on 30"- 36", 4" on 42"-48")
- EPDM Disc and o-rings, 14"-16" optional, 18"-48" standard
- Stainless steel fasteners: Type 304, Type 316
- Handwheel
- Spur or bevel geared actuator
- Position indicators

### Resilient wedge gate valve parts

Catalog Part No.	Description	Material	Material Standard
G-16	Bonnet Bolts & Nuts	Carbon Steel	SAE J429 (bolt) ASTM A563 (nut)
G-41	Stuffing Box Bolts & Nuts	Carbon Steel	SAE J429 (bolt) ASTM A563 (nut)
G-49	Stem O-rings (3)†	Nitrile	ASTM D2000
G-200	Wrench Nut Cap Screw	Carbon Steel	SAE J429
G-201	Stuffing Box O-ring†	Nitrile	ASTM D2000
G-202	Wrench Nut	Cast Iron+	ASTM A126 CL.B
G-203	Stem	Bronze	ASTM B138**
G-204	Hand Wheel (not shown)	Cast Iron+	ASTM A126 CL.B
G-205	Stem Nut	Bronze	ASTM B62
G-206	Guide Cap Bearings	Acetal	-
G-207	Stuffing Box	Ductile Iron++	ASTM A536 ▼
G-208	Anti-friction Washers (2)	Acetal	-
G-209	Wedge, Rubber Encapsulation	Ductile Iron* SBR†	ASTM A536 ▼ ASTM D2000
G-210	Bonnet	Ductile Iron	ASTM A536 ▼
G-211	Bonnet O-ring †	Nitrile	ASTM D2000
G-212	Body	Ductile Iron	ASTM A536 ▼

\* Fully encapsulated in molded rubber with no iron exposed

\*\*18" - 48" ASTM B584

†18" - 48" EPDM standard

++ 30"-48" are hot rolled steel ASTM A36

+ Manufacturers option to change material to Ductile iron ASTM A536

▼ Material strength ASTM A536 65-45 minimum

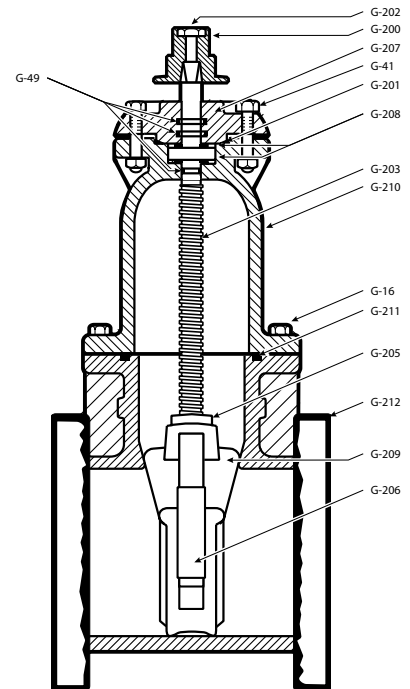

# 14"- 48" A-2361 D.I. RESILIENT WEDGE GATE VALVES - M.J. x FL.



# 10.17

Shaded area indicates change Rev. 4-14

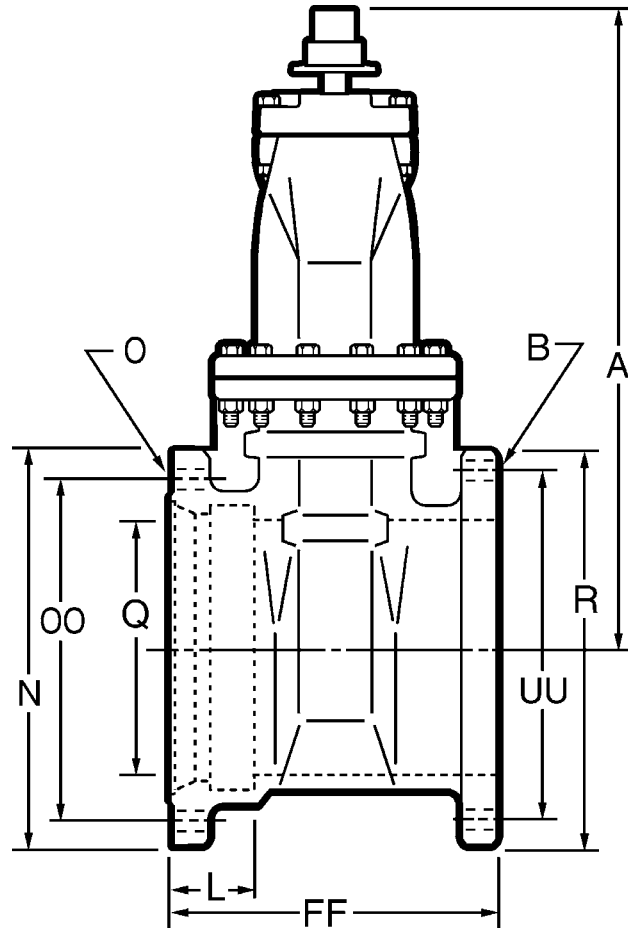

## Dimensions

Dimension	Nominal Size								
	14"	16"	18"	20"	24"	30"†	36"†	42"†	48"†
A	32.75	37.88	44.19	48.25	53.88	See A for Spur or Bevel Gear			
L	3.50	3.50	3.50	3.50	3.50	4.00	4.00	4.00	4.00
N	20.66	22.66	24.88	27.25	31.88	39.53	46.41	53.53	60.41
O (number and size of holes for MJ)	10--.88	12--.88	12--.88	14--.88	16--.88	20--1.125	24--1.125	28--1.38	32--1.38
Q (bore)	14.38	16.00	18.38	20.38	24.38	30.38	36.38	42.38	48.38
OO (bolt circle diameter for MJ)	18.75	21.00	23.25	25.50	30.00	36.88	43.75	50.62	57.50
R	21.00	23.50	25.00	27.50	32.00	38.75	46.00	53.00	59.50
UU (bolt circle diameter)	18.75	21.25	22.75	25.00	29.50	36.00	42.75	49.50	56.00
FF	17.41	17.91	19	19.75	21.75	29.75	33.75	40.19	43.86
B (number and size of holes for FL)	12--1.12	16--1.12	16--1.12	20--1.25	20--1.38	28--1.38	32--1.63	36--1.63	44--1.63
A - Spur Gear	40.49	43.58	49.41	53.01	59.15	70.81	83.08	97.74	109.70
A - Bevel Gear**	34.55	37.77	44.50	47.69	54.06	64.93	77.19	90.75	102.61
Turns to open (without gearing)	43.5	49	57	63	75	-	-	-	-
Turns to open (Spur gearing)	178	201	234	258	308	381	455	524	596
Turns to open (Bevel gearing)	174††	196††	228††	252††	300††	372††	444††	524††	596††
Weight*	693	850	1279	1795	2459	6457	8412	13083	19841

\*All dimensions are in inches. All weights are in pounds and are approximate. Weights for 30"-48" valves are with gearing; for all others without gearing.

\*\*Center line of operating nut to center line of valve.

†Spur or Bevel Gear must be used with 30", 36", 42", 48" valves.

††Turns shown for Bevel gearing. Valves with Bevel gearing: All Sizes - 4:1 ratio.

Rev. 7-16 Shaded area indicates changes

- Catalog number—  
**A-2361-20** Mechanical joint ends (with accessories unassembled)  
**A-2361-23** Mechanical joint ends (less accessories)
- Sizes – 14", 16", 18", 20", 24", 30", 36", 42", 48"
- Meets or exceeds all applicable requirements of ANSI/AWWA C515 Standard, UL 262 Listed, FM 1120/1130 Approved, and certified to ANSI/NSF 61 & 372
- Mechanical joint ends comply with ANSI/AWWA C111 Standard.
- Ductile Iron body and bonnet with nominal 10 mils MUELLER® Pro-Gard® Fusion Bonded Epoxy Coated interior and exterior surfaces; 42" and 48" valves coated with Mueller HP Epoxy
- Epoxy coating meets or exceeds all applicable requirements of ANSI/AWWA C550 Standard
- Ductile Iron wedge, symmetrical and fully encapsulated with molded rubber; no exposed iron.
- Non-rising stem (NRS)
- Triple O-ring seal (2 above the thrust collar and 1 below)
- 2" square wrench nut - open left or open right (30" - 48" require a Spur Gear or Bevel Gear)
- 250 psig (1725 kPa/17 barg) maximum working pressure; 500 psig (3450 kPa/35 barg) static test pressure
- 14" and 16" sizes – UL Listed, FM Approved: 250 psig (1725 kPa/17 barg)
- 18", 20" and 24" sizes – UL Listed: 175 psig (1200 kPa/12 barg)
- Mueller valves are designed for potable water applications



**A-2361-23**

### Options

See page 10.46 for more information on Resilient Wedge Gate Valve options

- Position indicators
- ASTM B98-C66100/H02 stem: 14"-16", ASTM B763-C99500: 18" - 48"
- Bypass 16" - 48" (2" on 16"-20"; 2.5" on 24"; 3" on 30"- 36", 4" on 42"-48")
- EPDM Disc and o-rings, 14"-16" optional, 18"-48" standard
- Handwheel
- Stainless Steel Stem Type 304, Type 316
- Spur or bevel geared actuator
- Stainless steel fasteners: Type 304, Type 316

### Resilient wedge gate valve parts

Catalog Part No.	Description	Material	Material Standard
G-16	Bonnet Bolts & Nuts	Carbon Steel	SAE J429 (bolt) ASTM A563 (nut)
G-41	Stuffing Box Bolts & Nuts	Carbon Steel	SAE J429 (bolt) ASTM A563 (nut)
G-49	Stem O-rings (3)†	Nitrile	ASTM D2000
G-200	Wrench Nut Cap Screw	Carbon Steel	SAE J429
G-201	Stuffing Box O-ring†	Nitrile	ASTM D2000
G-202	Wrench Nut	Cast Iron+	ASTM A126 CL.B
G-203	Stem	Bronze	ASTM B138**
G-204	Hand Wheel (not shown)	Cast Iron+	ASTM A126 CL.B
G-205	Stem Nut	Bronze	ASTM B62
G-206	Guide Cap Bearings	Acetal	-
G-207	Stuffing Box	Ductile Iron++	ASTM A536 ▼
G-208	Anti-friction Washers (2)	Acetal	-
G-209	Wedge, Rubber Encapsulation	Ductile Iron* SBR†	ASTM A536 ▼ ASTM D2000
G-210	Bonnet	Ductile Iron	ASTM A536 ▼
G-211	Bonnet O-ring †	Nitrile	ASTM D2000
G-212	Body	Ductile Iron	ASTM A536 ▼

\* Fully encapsulated in molded rubber with no iron exposed

\*\*18" - 48" ASTM B584

†18" - 48" EPDM standard

++30"-48" are hot rolled steel ASTM A36

+ Manufacturers option to change material to Ductile iron ASTM A536

▼ Material strength ASTM A536 65-45 minimum

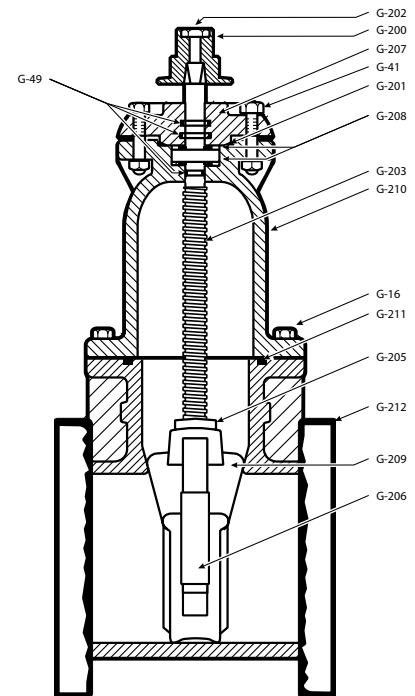

# 14" - 48" A-2361 D.I. RESILIENT WEDGE GATE VALVES - M.J. x M.J.



# 10.19

Shaded area indicates change Rev. 4-14

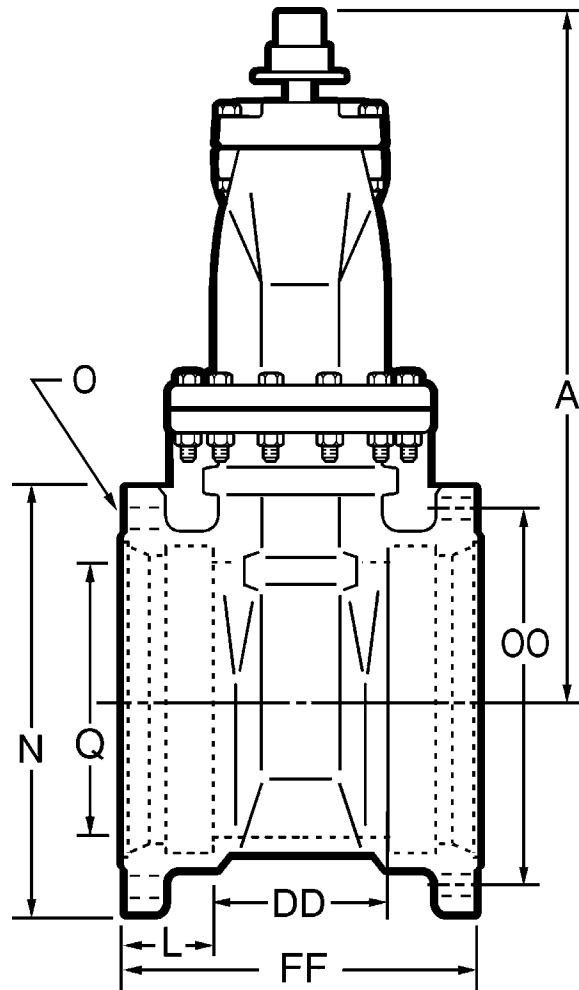

## Dimensions

Dimension	Nominal Size									
	14"	16"	18"	20"	24"	30"†	36"†	42"†	48"†	
A	32.75	37.88	44.19	48.25	53.88	See A for Spur or Bevel Gear				
L	3.50	3.50	3.50	3.50	3.50	4.00	4.00	4.00	4.00	
N	20.62	22.56	24.88	27.01	31.88	39.53	46.41	53.53	60.41	
O (number and size of holes for MJ)	10--.88	12--.88	12--.88	14--.88	16--.88	20--1.125	24--1.125	28--1.38	32--1.38	
Q (bore)	14.38	16.00	18.38	20.38	24.38	30.38	36.38	42.38	48.38	
OO (bolt circle diameter for MJ)	18.75	21.00	23.25	25.50	30.00	36.88	43.75	50.62	57.50	
R	21.00	23.50	25.00	27.50	32.00	38.75	46.00	53.00	59.50	
UU (bolt circle diameter)	18.75	21.25	22.75	25.00	29.50	36.00	42.75	49.50	56.00	
FF	19.75	19.75	21.00	21.50	23.50	33.50	37.50	42.37	44.72	
B (number and size of holes for FL)	12--1.12	16--1.12	16--1.12	20--1.25	20--1.38	28--1.38	32--1.63	36--1.63	44--1.63	
A - Spur Gear	40.49	43.58	49.41	53.01	59.15	70.81	83.08	97.74	109.70	
A - Bevel Gear**	34.55	37.77	44.50	47.69	54.06	64.93	77.19	90.75	102.61	
DD	12.36	12.55	13.90	14.13	16.06	25.56	29.34	34.58	36.80	
Turns to open (without gearing)	43.5	49	57	63	75	-	-	-	-	
Turns to open (Spur gearing)	178	201	234	258	308	381	455	524	596	
Turns to open (Bevel gearing)	174††	196††	228††	252††	300††	372††	444††	524††	596††	
Weight*	695	846	1274	1820	2438	6523	8400	13300	19700	

\*All dimensions are in inches. All weights are in pounds and are approximate. Weights for 30"-48" valves are with gearing; for all others without gearing.

\*\*Center line of operating nut to center line of valve.

†Spur or Bevel Gear must be used with 30", 36", 42", 48" valves.

††Turns shown for Bevel gearing. Valves with Bevel gearing: All Sizes - 4:1 ratio.

Rev. 7-16 Shaded area indicates changes

- Catalog number—  
**A-2361-38** Slip-on† ends with gasket  
**A-2361-40** Slip-on† ends less gasket
- Sizes – 14", 16"
- Meets or exceeds all applicable requirements of ANSI/AWWA C515 Standard, UL 262 Listed, FM 1120/1130 Approved, and certified to ANSI/NSF 61 & 372
- Slip-on ends fit plain end of classes 50 and 100 cast iron; ductile iron and AWWA C905 cast iron O.D. PVC
- Ductile iron body with nominal 10 mils MUELLER® Pro-Gard® Fusion Bonded Epoxy Coated interior and exterior surfaces
- Epoxy coating meets or exceeds all applicable requirements of ANSI/AWWA C550 Standard
- Ductile iron wedge, symmetrical and fully encapsulated with molded rubber; no exposed iron
- Non-rising stem (NRS)
- Triple O-ring seal (2 above the thrust collar and 1 below)
- 2" square wrench nut - open left or open right
- 250 psig (1725 kPa/17 barg) maximum working pressure; 500 psig (3450 kPa/35 barg) static test pressure
- UL Listed, FM Approved – 250 psig (1725 kPa/17 barg)
- Mueller valves are designed for potable water applications



**A-2361-40**

†Design and dimensions of the joint are manufactured under license of U.S. Pipe and Foundry Company.

### Options

See page 10.46 for more information on Resilient Wedge Gate Valve options

- Position indicators
- Spur or bevel geared actuator
- Stainless Steel fasteners: Type 304, Type 316
- Handwheel
- Stainless Steel stem: Type 304, Type 316
- ASTM B98-C66100/H02 stem
- EPDM Disc and O-rings

### Resilient wedge gate valve parts

Catalog Part No.	Description	Material	Material Standard
G-16	Bonnet Bolts & Nuts	Carbon Steel	SAE J429 (bolt) ASTM A563 (nut)
G-41	Stuffing Box Bolts & Nuts	Carbon Steel	SAE J429 (bolt) ASTM A563 (nut)
G-49	Stem O-rings (3)	Nitrile	ASTM D2000
G-200	Wrench Nut Cap Screw	Carbon Steel	SAE J429
G-201	Stuffing Box O-ring	Nitrile	ASTM D2000
G-202	Wrench Nut	Cast Iron+	ASTM A126 CL.B
G-203	Stem	Bronze	ASTM B138
G-204	Hand Wheel (not shown)	Cast Iron+	ASTM A126 CL.B
G-205	Stem Nut	Bronze	ASTM B62
G-206	Guide Cap Bearings	Acetal	-
G-207	Stuffing Box	Ductile Iron	ASTM A536 ▼
G-208	Anti-friction Washers (2)	Acetal	-
G-209	Wedge, Rubber Encapsulation	Ductile Iron SBR*	ASTM A536 ▼ ASTM D2000
G-210	Bonnet	Ductile Iron	ASTM A536 ▼
G-211	Bonnet O-ring	Nitrile	ASTM D2000
G-212	Body	Ductile Iron	ASTM A536 ▼

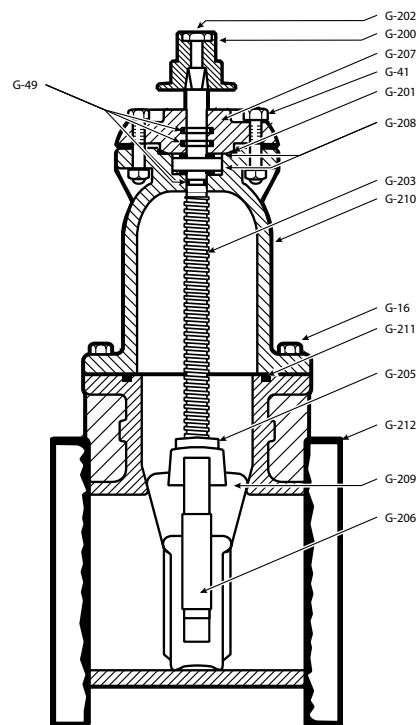

\* Fully encapsulated in molded rubber with no iron exposed  
 + Manufacturers option to change material to Ductile iron ASTM A536  
 ▼ Material strength ASTM A536 65-45 minimum



# 14" & 16" A-2361 D.I. RESILIENT WEDGE GATE VALVES - SL. x SL.



# 10.21

Shaded area indicates change Rev. 4-14

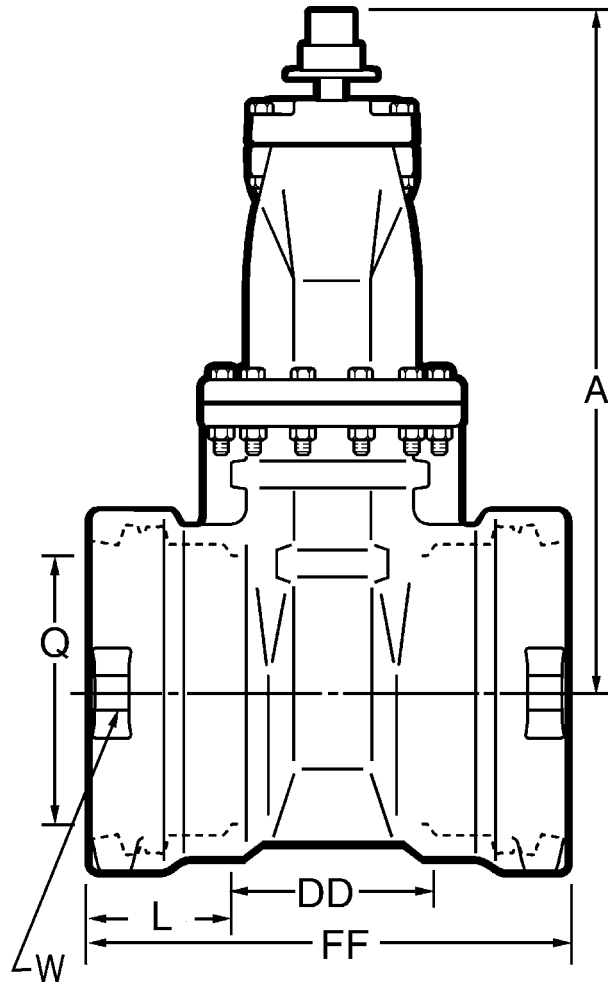

## Dimensions

Dimension	Nominal Size	
	14"	16"
A	32.75	37.88
Q (bore)	14.38	16.00
W (distance between strapping lug holes across face of valve ends)	22.50	23.12
FF	24.42	25.32
L	6.00	6.00
DD	12.42	13.32
A - Spur Gear	40.49	43.58
A - Bevel Gear**	34.55	37.77
Turns to open (without gearing)	43.5	49
Turns to open (Spur gearing)	178	201
Turns to open (Bevel gearing)	174	196
Weight*	705	885

\*All dimensions are in inches. All weights are in pounds and are approximate.

\*\*Center line of operating nut to center line of valve.

Rev. 7-16 Shaded area indicates changes

- Catalog number–  
**A-2361-41** Slip-on† end (with gasket) x flange end  
**A-2361-43** Slip-on† end (less gasket) x flange end
- Sizes – 14", 16"
- Meets or exceeds all applicable requirements of ANSI/AWWA C515 Standard, UL 262 Listed, FM 1120/1130 Approved, and certified to ANSI/NSF 61 & 372
- Slip-on ends fit plain end of classes 50 and 100 cast iron; ductile iron and AWWA C905 cast iron O.D. PVC
- Flanged end drilling complies with ASME/ANSI B16.1 Class 125
- Ductile iron body and bonnet with nominal 10 mils MUELLER® Pro-Gard® Fusion Bonded Epoxy Coated interior and exterior surfaces
- Epoxy coating meets or exceeds all applicable requirements of ANSI/AWWA C550 Standard
- Ductile iron wedge, symmetrical and fully encapsulated with molded rubber; no exposed iron
- Non-rising stem (NRS)
- Triple O-ring seal (2 above the thrust collar and 1 below)
- 2" square wrench nut - open left or open right
- 250 psig (1725 kPa/17 barg) maximum working pressure; 500 psig (3450 kPa/35 barg) static test pressure
- UL Listed, FM Approved – 250 psig (1725 kPa/17 barg)
- Mueller valves are designed for potable water applications



**A-2361-43**

†Design and dimensions of the joint are manufactured under license of U.S. Pipe and Foundry Company.

### Options

See page 10.46 for more information on Resilient Wedge Gate Valve options

- Position indicators
- Spur or bevel geared actuator
- Stainless Steel fasteners: Type 304, Type 316
- ASTM B98-C66100/H02 stem
- Handwheel
- Stainless Steel stem: Type 304, Type 316
- EPDM disc and o-rings

### Resilient wedge gate valve parts

Catalog Part No.	Description	Material	Material Standard
G-16	Bonnet Bolts & Nuts	Carbon Steel	SAE J429 (bolt) ASTM A563 (nut)
G-41	Stuffing Box Bolts & Nuts	Carbon Steel	SAE J429 (bolt) ASTM A563 (nut)
G-49	Stem O-rings (3)	Nitrile	ASTM D2000
G-200	Wrench Nut Cap Screw	Carbon Steel	SAE J429
G-201	Stuffing Box O-ring	Nitrile	ASTM D2000
G-202	Wrench Nut	Cast Iron+	ASTM A126 CL.B
G-203	Stem	Bronze	ASTM B138
G-204	Hand Wheel (not shown)	Cast Iron+	ASTM A126 CL.B
G-205	Stem Nut	Bronze	ASTM B62
G-206	Guide Cap Bearings	Acetal	-
G-207	Stuffing Box	Ductile Iron	ASTM A536 ▼
G-208	Anti-friction Washers (2)	Acetal	-
G-209	Wedge, Rubber Encapsulation	Ductile Iron SBR	ASTM A536 ▼ ASTM D2000
G-210	Bonnet	Ductile Iron	ASTM A536 ▼
G-211	Bonnet O-ring	Nitrile	ASTM D2000
G-212	Body	Ductile Iron	ASTM A536 ▼

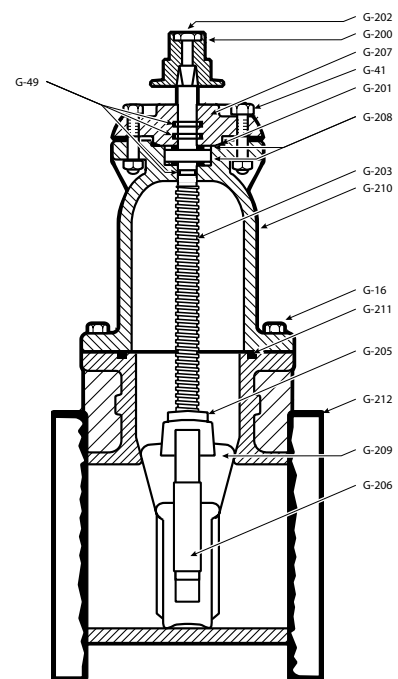

\* Fully encapsulated in molded rubber with no iron exposed  
+ Manufacturer's option to change material to Ductile iron ASTM A536  
▼ Material strength ASTM A536 65-45 minimum

# 14" & 16" A-2361 D.I. RESILIENT WEDGE GATE VALVES - SL. x FL.



# 10.23

Shaded area indicates change Rev. 4-14

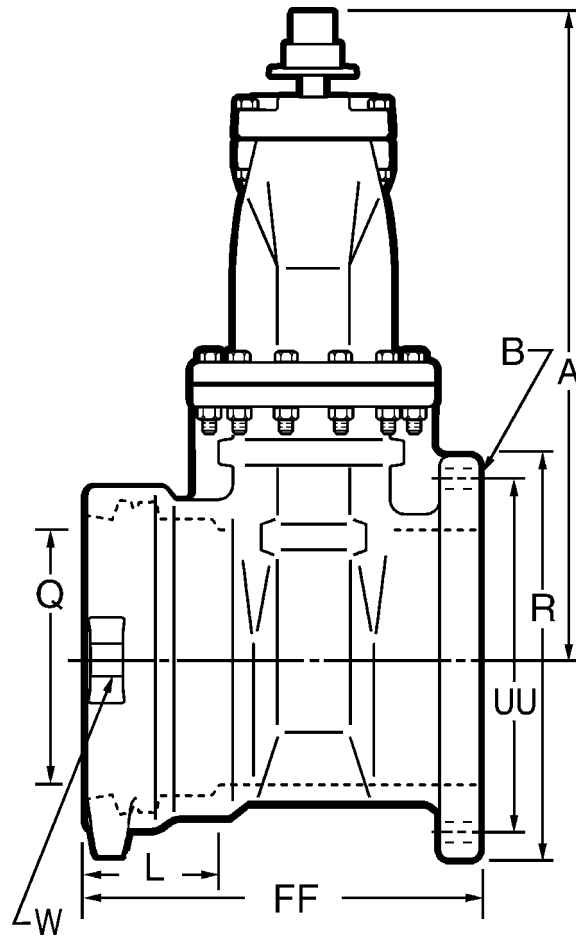

## Dimensions

Dimension	Nominal Size	
	14"	16"
A	32.75	37.88
Q (bore)	14.38	16.00
W (distance between strapping lug holes across face of valve ends)	22.50	23.12
L	6.00	6.00
R	21.00	23.50
UU	18.75	21.25
B (number and size of holes)	12--1.12	16--1.12
FF	19.74	20.69
A - Spur Gear	40.49	43.58
A - Bevel Gear**	34.55	37.77
Turns to open (without gearing)	43.5	49
Turns to open (Spur gearing)	178	201
Turns to open (Bevel gearing)	198	221
Weight*	689	873

\*All dimensions are in inches. All weights are in pounds and are approximate.

\*\*Center line of operating nut to center line of valve.

Rev. 7-16 Shaded area indicates changes

- Catalog number–
  - A-2361-76** Aqua-Grip ends x flanged ends for DIPS pipe in sizes 4", 6", 8", 10", 12"
  - A-2361-86** Aqua-Grip ends x flanged ends for IPS pipe in sizes 4", 6", 8"
- Meets or exceeds all applicable requirements of ANSI/AWWA C515 Standard, UL 262 Listed, FM 1120/1130 Approved, and certified to ANSI/NSF 61 & 372
- Flanged end drilling complies with ASME/ANSI B16.1 Class 125
- Ductile iron body and bonnet with nominal 10 mils MUELLER Pro-Gard® Fusion Bonded Epoxy Coated interior and exterior surfaces
- Epoxy coating meets or exceeds all applicable requirements of ANSI/AWWA C550 Standard
- Iron wedge, symmetrical and fully encapsulated with molded rubber; no exposed iron
- Non-rising stem (NRS)
- Triple O-ring seal (2 above the thrust collar and 1 below)
- 2" square wrench nut - open left or open right
- 250 psig (1725 kPa/17 barg) maximum working pressure; 500 psig (3450 kPa/35 barg) static test pressure
- UL Listed, FM Approved – 200 psig (1375 kPa/14 barg)
- Mueller valves are designed for potable water applications



**A-2361-76**

### Options

See page 10.46 for more information on Resilient Wedge Gate Valve options

- Position indicators
- Stainless steel fasteners: Type 316
- Stainless steel stem: Type 304, Type 316
- ASTM B98-C66100/H02 stem
- Handwheel
- EPDM Disc and o-ring

### Resilient wedge gate valve parts

Catalog Part No.	Description	Material	Material Standard
G-16	Bonnet Bolts & Nuts	304 Stainless Steel	ASTM F593 (bolt) ASTM F594 (nut)
G-41	Stuffing Box Bolts & Nuts	304 Stainless Steel	ASTM F593 (bolt) ASTM F594 (nut)
G-49	Stem O-rings (3)	Nitrile	ASTM D2000
G-200	Wrench Nut Cap Screw	304 Stainless Steel	ASTM F593
G-201	Stuffing Box O-ring	Nitrile	ASTM D2000
G-202	Wrench Nut	Ductile iron	ASTM A536 ▼
G-203	Stem	Bronze	ASTM B138
G-204	Hand Wheel (not shown)	Cast Iron +	ASTM A126 CL.B
G-205	Stem Nut	Bronze	ASTM B584
G-206	Guide Cap Bearings	Acetal	-
G-207	Stuffing Box with dirt seal	Cast Iron + Nitrile	ASTM A536 ▼ ASTM D2000
G-208	Anti-friction Washers (2)	Acetal	-
G-209	Wedge, Rubber Encapsulation	Ductile Iron * SBR	ASTM A536 ▼ ASTM D2000
G-210	Bonnet	Ductile Iron	ASTM A536 ▼
G-211	Bonnet O-ring	Nitrile	ASTM D2000
G-212	Body	Ductile Iron	ASTM A536 ▼
G-213	Double O-ring**	EPDM	ASTM D2000
G-214	Intermediate ring**	Ductile Iron	ASTM A536 ▼
G-215	Gripper ring**	Ductile Iron	ASTM A536 ▼
G-216	End ring**	Ductile Iron	ASTM A536 ▼
G-217	Breakaway Nut with washer***	Steel	ASTM A108 ▼
G-218	T-head Bolt***	Steel	ASTM A242

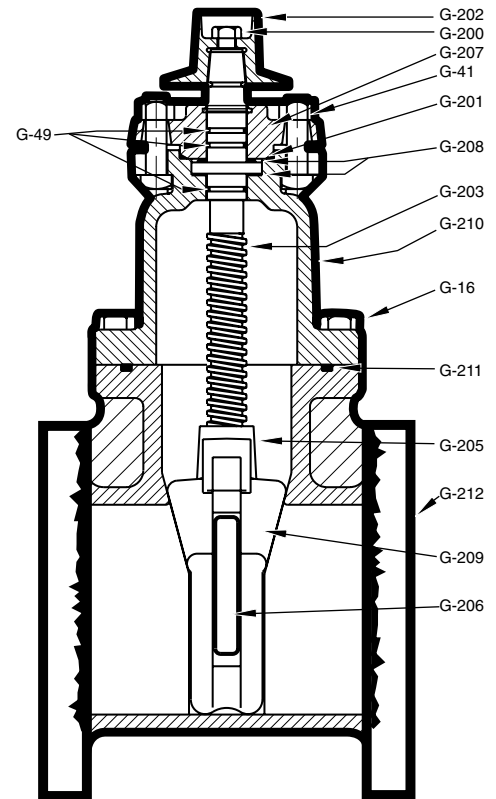

\*Fully encapsulated in molded rubber with no iron exposed.

\*\*Parts for Aqua-Grip connection not shown – one required for each Aqua-Grip connection.

\*\*\*Not shown. See dimension drawing on next page for number require for each size Aqua-Grip connection.

+ Manufacturers option to change material to Ductile iron ASTM A536

▼ Material strength ASTM A536 65-45 minimum

**4" - 12" A-2361 RESILIENT WEDGE GATE VALVES WITH AQUA-GRIP® x FL. ENDS**



**10.25**

Shaded area indicates change Rev. 4-14

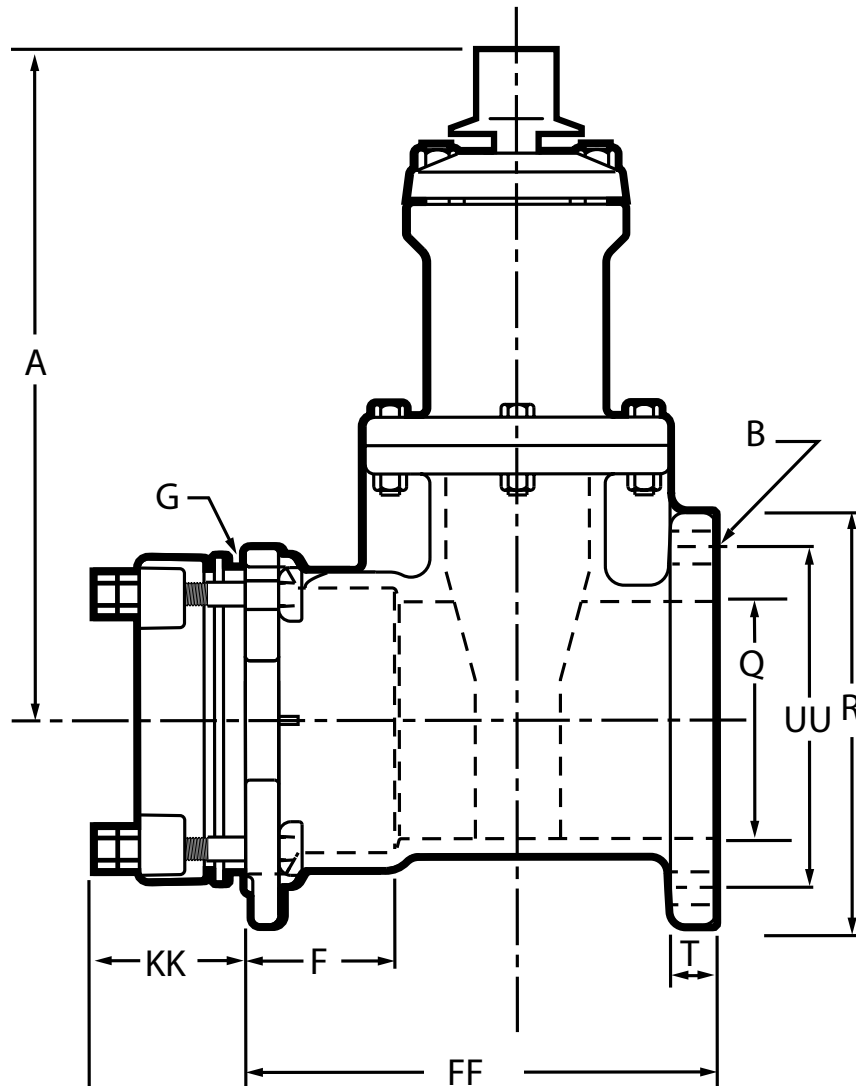

**Dimensions**

Dimension	Nominal Size				
	4"	6"	8"	10"	12"
A	14.19	18.00	21.50	25.50	28.62
B (number and size of holes for FL)	8--.75	8--.88	8--.88	12--1.00	12--1.00
F	3.70	3.70	3.70	3.89	3.89
G (number and size of holes for Aqua-Grip)	4--.88	4--.88	6--.88	8--.88	8--.88
T	.87	1.05	1.05	1.06	1.12
R	9.00	11.00	13.50	16.00	9.00
Q (bore)	4.30	6.30	2.30	10.30	12.30
FF	10.93	12.9	14.28	15.58	16.51
KK	2.75	3.75	3.75	3.75	3.75
UU (bolt circle diameter for FL)	7.50	9.50	11.75	14.25	17.00
Turns to open	14	20.5	26.5	33.0	38.5
Weight*	98	153	246	351	481

\*All dimensions are in inches. All weights are in approximate pounds.

Rev. 7-16 Shaded area indicates changes

- Catalog number–  
**A-2361-77** Aqua-Grip ends x Aqua-Grip ends for DIPS pipe in sizes 4", 6", 8", 10", 12"  
**A-2361-87** Aqua-Grip ends x Aqua-Grip ends for IPS pipe in sizes 4", 6", 8"
- Meets or exceeds all applicable requirements of ANSI/AWWA C515 Standard, UL 262 Listed, FM 1120/1130 Approved, and certified to ANSI/NSF 61 & 372
- Ductile Iron body and bonnet with nominal 10 mils MUELLER Pro-Gard® Fusion Bonded Epoxy Coated interior and exterior surfaces
- Epoxy coating meets or exceeds all applicable requirements of ANSI/AWWA C550 Standard
- Iron wedge, symmetrical and fully encapsulated with molded rubber; no exposed iron
- Non-rising stem (NRS)
- Triple O-ring seal (2 above the thrust collar and 1 below)
- 2" square wrench nut - open left or open right
- 250 psig (1725 kPa/17 barg) maximum working pressure; 500 psig (3450 kPa/35 barg) static test pressure
- UL Listed, FM Approved – 200 psig (1375 kPa/14 barg)
- Mueller valves are designed for potable water applications



A-2361-77

### Options

See page 10.46 for more information on Resilient Wedge Gate Valve options

- Position indicators
- Stainless steel fasteners: Type 316
- Stainless steel stem: Type 304, Type 316
- ASTM B98-C66100/H02 stem
- Handwheel
- EPDM Disc and o-ring

### Resilient wedge gate valve parts

Catalog Part No.	Description	Material	Material Standard
G-16	Bonnet Bolts & Nuts	304 Stainless Steel	ASTM F593 (bolt) ASTM F594 (nut)
G-41	Stuffing Box Bolts & Nuts	304 Stainless Steel	ASTM F593 (bolt) ASTM F594 (nut)
G-49	Stem O-rings (3)	Nitrile	ASTM D2000
G-200	Wrench Nut Cap Screw	304 Stainless Steel	ASTM F593
G-201	Stuffing Box O-ring	Nitrile	ASTM D2000
G-202	Wrench Nut	Ductile iron	ASTMA536 ▼
G-203	Stem	Bronze	ASTM B138
G-204	Hand Wheel (not shown)	Cast Iron	ASTM A126 CL.B
G-205	Stem Nut	Bronze	ASTM B584
G-206	Guide Cap Bearings	Acetal	-
G-207	Stuffing Box with dirt seal	Cast Iron + Nitrile	ASTM A126 CL.B ASTM D2000
G-208	Anti-friction Washers (2)	Acetal	-
G-209	Wedge, Rubber Encapsulation	Ductile iron SBR	ASTMA536 ▼ ASTM D2000
G-210	Bonnet	Ductile Iron	ASTMA536 ▼
G-211	Bonnet O-ring	Nitrile	ASTM D2000
G-212	Body	Ductile Iron	ASTMA536 ▼
G-213	Double O-ring**	EPDM	ASTM D2000
G-214	Intermediate ring**	Ductile Iron	ASTMA536 ▼
G-215	Gripper ring**	Ductile Iron	ASTMA536 ▼
G-216	End ring**	Ductile Iron	ASTMA536 ▼
G-217	Breakaway Nut with washer***	Steel	ASTM A108
G-218	T-head Bolt***	Steel	ASTM A242

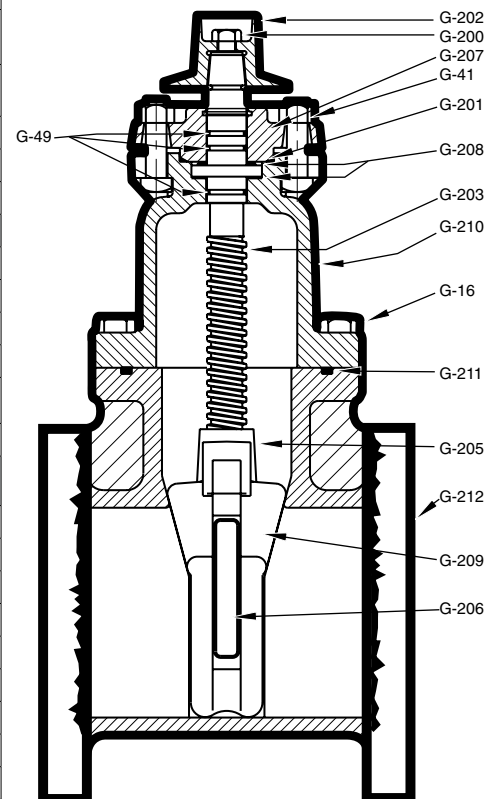

\*Fully encapsulated in molded rubber with no iron exposed.

\*\*Parts for Aqua-Grip connection not shown – one required for each Aqua-Grip connection.

\*\*\*Not shown. See dimension drawing on next page for number require for each size Aqua-Grip connection.

+ Manufacturers option to change material to Ductile iron ASTM A536

▼ Material strength ASTM A536 65-45 minimum

**4" - 12" A-2361 RESILIENT WEDGE GATE  
VALVES WITH AQUA-GRIP® x AQUA-GRIP ENDS**



**10.27**

Shaded area indicates change Rev. 4-14

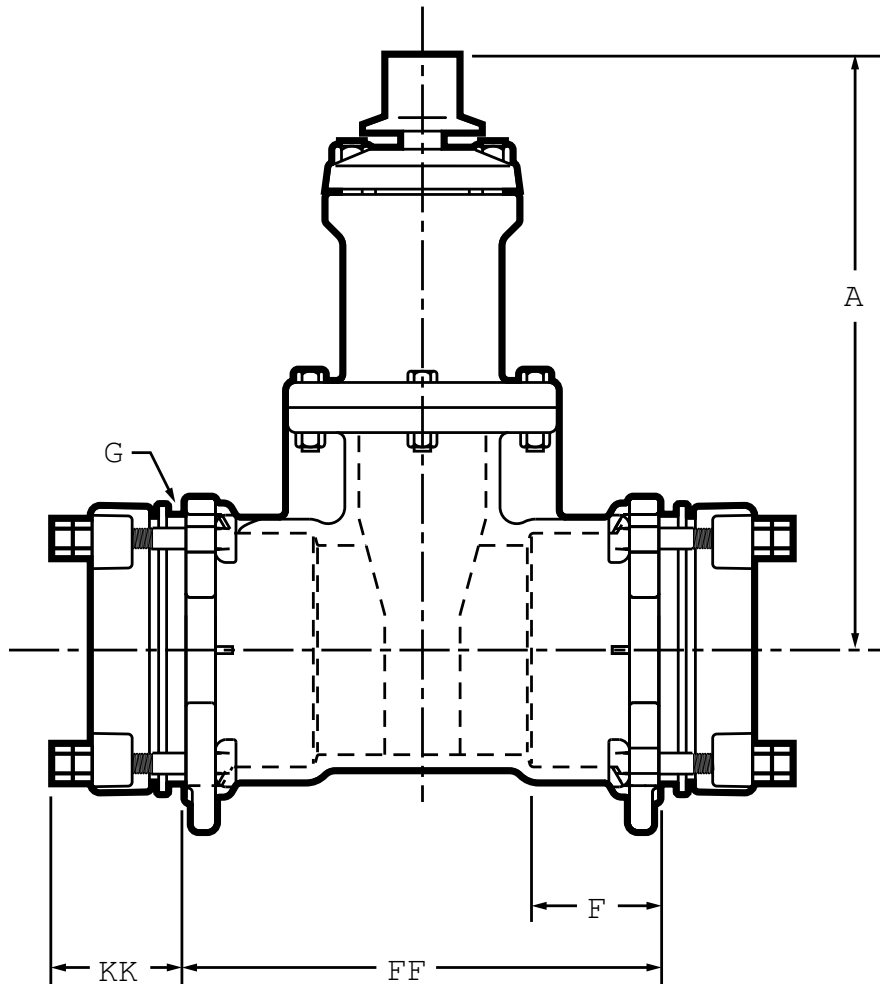

**Dimensions**

Dimension	Nominal Size				
	4"	6"	8"	10"	12"
A	14.19	18.00	21.50	25.50	28.62
FF	12.68	15.12	16.94	18.06	18.90
G (number and size of holes for Aqua-Grip)	4--.88	4--.88	6--.88	8--.88	8--.88
F	3.70	3.70	3.70	3.75	3.75
KK	2.75	3.75	3.75	3.75	3.75
Turns to open	14	20.5	26.5	33.0	38.5
Weight*	113	168	277	385	516

\*All dimensions are in inches. All weights are in approximate pounds.

Rev. 7-16 Shaded area indicates changes

- Catalog number–  
**A-2361-78** Aqua-Grip ends x mechanical joint for DIPS pipe in sizes 4", 6", 8", 10", 12"  
**A-2361-88** Aqua-Grip ends x mechanical joint for IPS pipe in sizes 4", 6", 8"
- Meets or exceeds all applicable requirements of ANSI/AWWA C515 Standard, UL 262 Listed, FM 1120/1130 Approved, and certified to ANSI/NSF 61 & 372
- Ductile Iron body and bonnet with nominal 10 mils MUELLER® Pro-Gard® Fusion Bonded Epoxy Coated interior and exterior surfaces.
- Epoxy coating meets or exceeds all applicable requirements of ANSI/AWWA C550 Standard
- Iron wedge, symmetrical and fully encapsulated with molded rubber; no exposed iron
- Non-rising stem (NRS)
- Triple O-ring seal (2 above the thrust collar and 1 below)
- 2" square wrench nut - open left or open right
- 250 psig (1725 kPa/17 barg) maximum working pressure; 500 psig (3450 kPa/35 barg) static test pressure
- UL Listed, FM Approved – 200 psig (1375 kPa/14 barg)
- Mueller valves are designed for potable water applications



**A-2361-78**

### Options

See page 10.40 for more information on Resilient Wedge Gate Valve options

- Position indicators
- ASTM B98-C66100/H02 stem
- Stainless steel fasteners: Type 316
- Handwheel
- Stainless steel stem: Type 304, Type 316
- EPDM Disc and o-ring

### Resilient wedge gate valve parts

Catalog Part No.	Description	Material	Material Standard
G-16	Bonnet Bolts & Nuts	304 Stainless Steel	ASTM F593 (bolt) ASTM F594 (nut)
G-41	Stuffing Box Bolts & Nuts	304 Stainless Steel	ASTM F593 (bolt) ASTM F594 (nut)
G-49	Stem O-rings (3)	Nitrile	ASTM D2000
G-200	Wrench Nut Cap Screw	304 Stainless Steel	ASTM F593
G-201	Stuffing Box O-ring	Nitrile	ASTM D2000
G-202	Wrench Nut	Ductile iron	ASTM A536 ▼
G-203	Stem	Bronze	ASTM B138
G-204	Hand Wheel (not shown)	Cast Iron	ASTM A126 CL.B
G-205	Stem Nut	Bronze	ASTM B584
G-206	Guide Cap Bearings	Acetal	-
G-207	Stuffing Box with dirt seal	Cast Iron + Nitrile	ASTM A126 CL.B ASTM D2000
G-208	Anti-friction Washers (2)	Acetal	-
G-209	Wedge, Rubber Encapsulation	Ductile Iron* + SBR	ASTM A536 ▼ ASTM D2000
G-210	Bonnet	Ductile Iron	ASTM A536 ▼
G-211	Bonnet O-ring	Nitrile	ASTM D2000
G-212	Body	Ductile Iron	ASTM A536 ▼
G-213	Double O-ring**	EPDM	ASTM D2000
G-214	Intermediate ring**	Ductile Iron	ASTM A536 ▼
G-215	Gripper ring**	Ductile Iron	ASTM A536 ▼
G-216	End ring**	Ductile Iron	ASTM A536 ▼
G-217	Breakaway Nut with washer***	Steel	ASTM A108
G-218	T-head Bolt***	Steel	ASTM A242

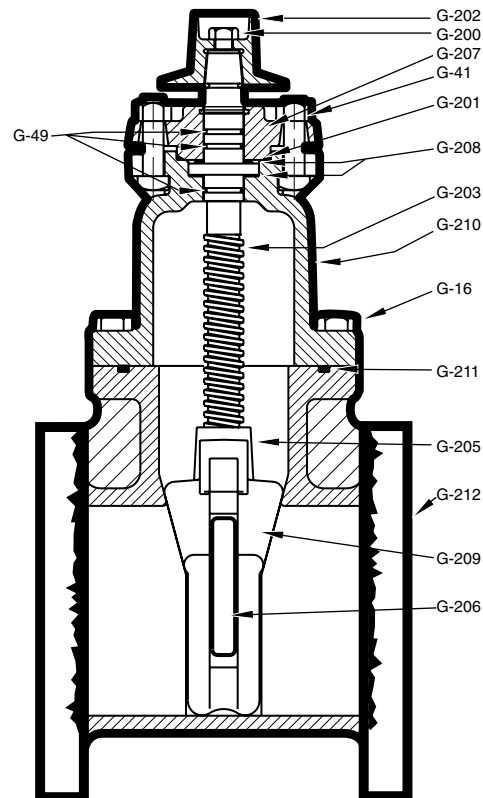

\*Fully encapsulated in molded rubber with no iron exposed.

\*\*Parts for Aqua-Grip connection not shown – one required for each Aqua-Grip connection.

\*\*\*Not shown. See dimension drawing on next page for number require for each size Aqua-Grip connection.

+ Manufacturers option to change material to Ductile iron ASTM A536

▼ Material strength ASTM A536 65-45 minimum



**4" - 12" A-2361 RESILIENT WEDGE GATE VALVES WITH AQUA-GRIP® x M.J. ENDS**



**10.29**

Shaded area indicates change Rev. 4-14

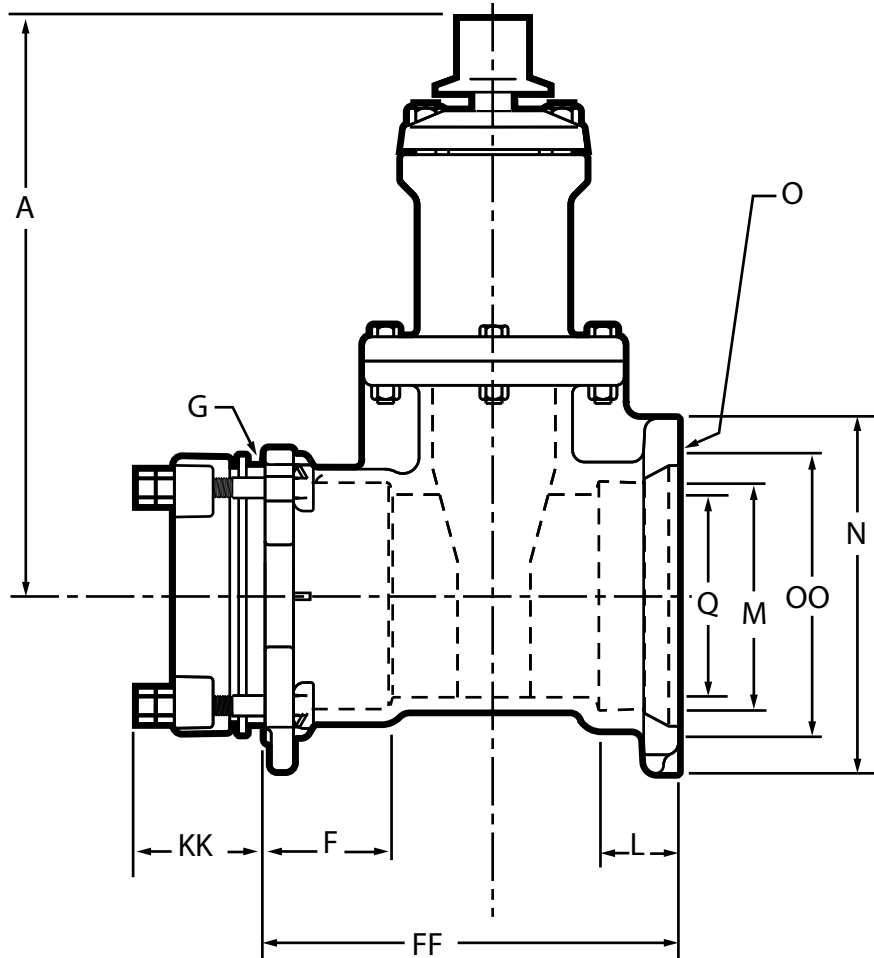

**Dimensions**

Dimension	Nominal Size				
	4"	6"	8"	10"	12"
A	14.19	18.00	21.50	25.50	28.62
F	3.70	3.70	3.70	3.89	3.89
G (number and size of holes for Aqua-Grip)	4--.88	4--.88	6--.88	8--.88	8--.88
L	2.50	2.50	2.50	2.50	2.50
M	4.90	7.06	9.22	11.20	13.37
N	9.03	11.06	13.31	15.63	17.88
O (number and size of holes for MJ)	4--.88	6--.88	6--.88	8--.88	8--.88
FF	11.34	13.37	14.81	16.4	16.87
Q	4.30	6.30	8.30	10.30	12.30
KK	2.75	3.75	3.75	3.75	3.75
OO (bolt circle diameter for MJ)	7.50	9.50	11.75	14.00	16.25
Turns to open	14	20.5	26.5	33.0	38.5
Weight*	98	151	240	348	467

Rev. 7-16 Shaded area indicates changes

- Catalog number–
  - A-2362-20** Mechanical joint ends (with accessories unassembled)
  - A-2362-23** Mechanical joint ends (less accessories)
  - A-2362-25** Mechanical joint ends (with transition gaskets accessories unassembled)
- Sizes – 3", 4", 6", 8", 10", 12"
- Meets or exceeds all applicable requirements of ANSI/AWWA C509 and C515, UL 262 Listed, FM 1120/1130 Approved, and certified to ANSI/NSF 61 & 372
- Standard mechanical joint ends comply with ANSI/AWWA C111
- Iron body with nominal 10 mils MUELLER® Pro-Gard® Fusion Bonded Epoxy Coated interior and exterior surfaces
- Epoxy coating meets or exceeds all applicable requirements of ANSI/AWWA C550 Standard
- Iron wedge, symmetrical and fully encapsulated with molded rubber; no exposed iron
- Non-rising stem (NRS)
- Triple O-ring seal (2 above the thrust collar and 1 below)
- 2" square wrench nut - open left or open right
- 250 psig (1725 kPa/17 barg) maximum working pressure; 500 psig (3450 kPa/35 barg) static test pressure
- UL Listed, FM Approved: 200 psig (1375 kPa/14 barg)
- Mueller valves are designed for potable water applications



**A-2362-20**

### Options

See page 10.46 for more information on Resilient Wedge Gate Valve options

- Position indicators
- Stainless steel fasteners: Type 316
- Stainless steel stem: Type 304, Type 316
- ASTM B98-C66100/H02 stem
- Handwheel
- EPDM Disc and o-rings

### Resilient wedge gate valve parts

Catalog Part No.	Description	Material	Material Standard
G-16	Bonnet Bolts & Nuts	304 Stainless Steel	ASTM F593 (bolt) ASTM F594 (nut)
G-41	Stuffing Box Bolts & Nuts	304 Stainless Steel	ASTM F593 (bolt) ASTM F594 (nut)
G-49	Stem O-rings (3)	Nitrile	ASTM D2000
G-200	Wrench Nut Cap Screw	304 Stainless Steel	ASTM F593
G-201	Stuffing Box O-ring	Nitrile	ASTM D2000
G-202	Wrench Nut	Ductile Iron	ASTMA536 ▼
G-203	Stem	Bronze	ASTM B138
G-204	Hand Wheel (not shown)	Cast Iron +	ASTMA126 CL.B
G-205	Stem Nut	Bronze	ASTM B62
G-206	Guide Cap Bearings	Acetal	-
G-207	Stuffing Box with dirt seal**	Cast Iron + Nitrile	ASTMA126 CL.B ASTM D200
G-208	Anti-friction Washers (2)	Acetal	-
G-209	Wedge, Rubber Encapsulation	Ductile Iron* SBR	ASTMA536 ▼ ASTM D2000
G-210**	Bonnet	Ductile Iron	ASTMA536 ▼
G-211**	Bonnet gasket	Nitrile	ASTM D2000
G-212**	Body	Ductile Iron	ASTMA536 ▼

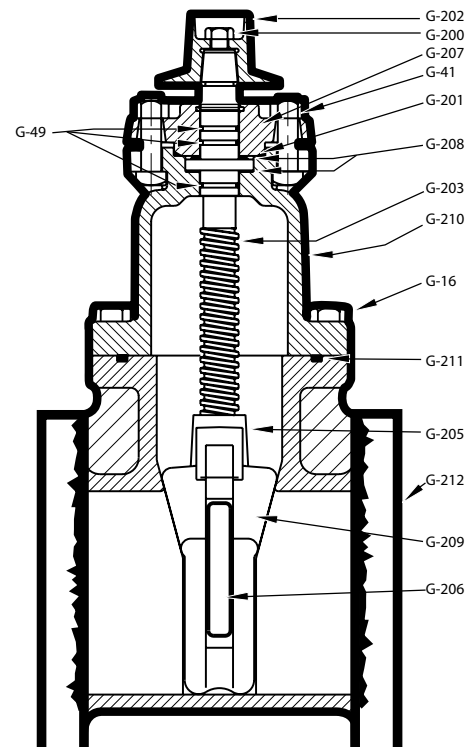

\*Fully encapsulated in molded rubber with no iron exposed

\*\*Dirt seal on 4" - 12" valves

▼ Material strength ASTM A536 65-45-minimum

+ Manufacturer's option to upgrade material to ductile iron ASTM A536

**3" - 12" A-2362 RESILIENT WEDGE  
GATE VALVES - M.J. x M.J.**



**10.31**

Shaded area indicates change Rev. 5-15

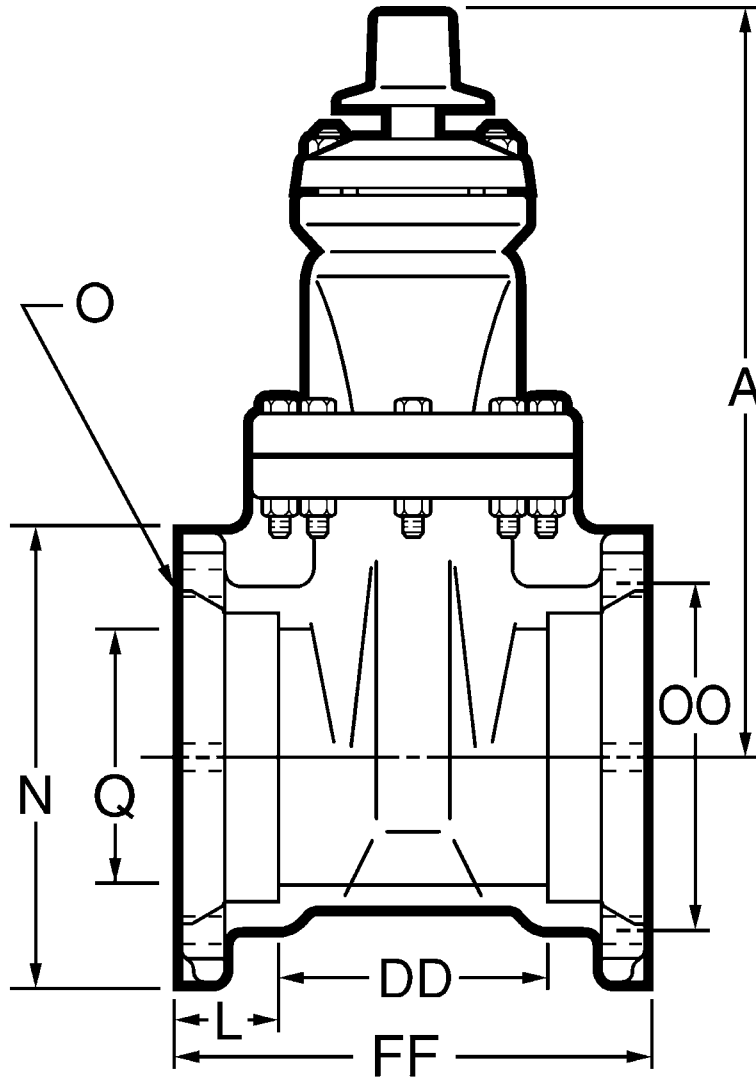

**Dimensions**

Dimension	Nominal Size					
	3"	4"	6"	8"	10"	12"
A	12.38	14.9	18.00	21.50	25.50	28.62
FF	9.62	10.00	11.60	12.68	14.88	15
L	2.50	2.50	2.50	2.50	2.50	2.50
N	7.50	9.12	11.12	13.37	15.62	17.88
O (number and size of holes)	4--.88	4--.88	6--.88	6--.88	8--.88	8--.88
DD	4.62	5.00	6.60	7.68	9.88	10
Q	3.30	4.30	6.30	8.30	10.30	12.30
OO (bolt circle diameter)	6.19	7.50	9.50	11.75	14.00	16.25
Turns to open	11	14	20.5	26.5	33.0	38.5
Weight*	83	120	186	280	405	540

\*All dimensions are in inches. All weights include accessories are in pounds and are approximate.

Rev. 7-16 Shaded area indicates changes

- Catalog number – **A-2362-6** flanged ends
- Sizes – 3", 4", 6", 8", 10", 12"
- Meets or exceeds all applicable requirements of ANSI/AWWA C509 and C515, UL 262 Listed, FM 1120/1130 Approved, and certified to ANSI/NSF 61 & 372†
- Flanged end drilling complies with ASME/ANSI B16.1 Class 125
- Iron body with nominal 10 mils MUELLER® Pro-Guard® Fusion Bonded Epoxy Coated interior and exterior surfaces
- Epoxy coating meets or exceeds all applicable requirements of ANSI/AWWA C550 Standard
- Iron wedge, symmetrical and fully encapsulated with molded rubber; no exposed iron
- Non-rising stem (NRS)
- Triple O-ring seal (2 above the thrust collar and 1 below)
- 2" square wrench nut - open left or open right
- 250 psig (1725 kPa/17 barg) maximum working pressure; 500 psig (3450 kPa/35 barg) static test pressure
- UL Listed, FM Approved: 200 psig (1375 kPa/14 barg)
- Mueller valves are designed for potable water applications

† Approved for backflow prevention devices by USC (for 4" - 10" sizes)



**A-2362-6**

### Options

See page 10.46 for more information on Resilient Wedge Gate Valve options

- Post indicators
- Stainless steel fasteners: Type 316
- Stainless steel stem: Type 304, Type 316
- 2" square wrench nut
- P/N 10/16 Drilling
- EPDM Disc and O-rings
- ASTM B98-C66100/H02 stem

### Resilient wedge gate valve parts

Catalog Part No.	Description	Material	Material Standard
G-16	Bonnet Bolts & Nuts	304 Stainless Steel	ASTM F593 (bolt) ASTM F594 (nut)
G-41	Stuffing Box Bolts & Nuts	304 Stainless Steel	ASTM F593 (bolt) ASTM F594 (nut)
G-49	Stem O-rings (3)	Nitrile	ASTM D2000
G-200	Wrench Nut Cap Screw	304 Stainless Steel	ASTM F593
G-201	Stuffing Box O-ring	Nitrile	ASTM D2000
G-202	Wrench Nut	Ductile Iron	ASTM A536 ▼
G-203	Stem	Bronze	ASTM B138
G-204	Hand Wheel	Cast Iron +	ASTM A126 CL.B
G-205	Stem Nut	Bronze	ASTM B62
G-206	Guide Cap Bearings	Acetal	-
G-207	Stuffing Box with dirt seal**	Cast Iron + Nitrile	ASTM A126 CL.B ASTM D2000
G-208	Anti-friction Washers (2)	Acetal	-
G-209	Wedge, Rubber Encapsulation	Ductile Iron* SBR	ASTM A536 ▼ ASTM D2000
G-210**	Bonnet	Ductile Iron	ASTM A536 ▼
G-211**	Bonnet gasket	Nitrile	ASTM D2000
G-212**	Body	Ductile Iron	ASTM A536 ▼

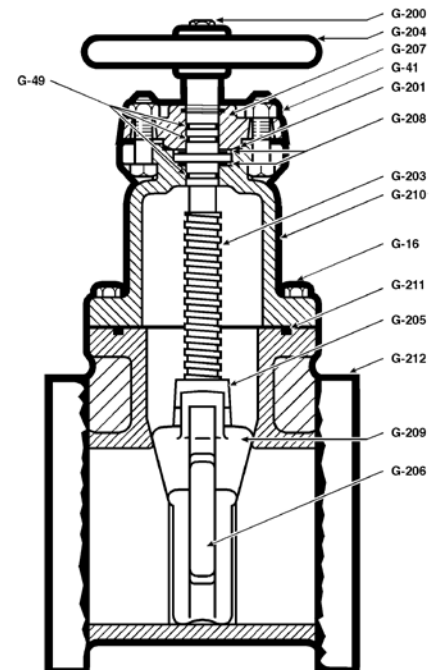

\*Fully encapsulated in molded rubber with no iron exposed

\*\*Dirt seal on 4" - 12" valves

▼ Material strength ASTM A536 65-45 minimum

+ Manufacturer's option to upgrade material to ductile iron ASTM A536

**3" - 12" A-2362 RESILIENT WEDGE  
GATE VALVES - FL. x FL.**



**10.33**

Shaded area indicates change Rev. 5-15

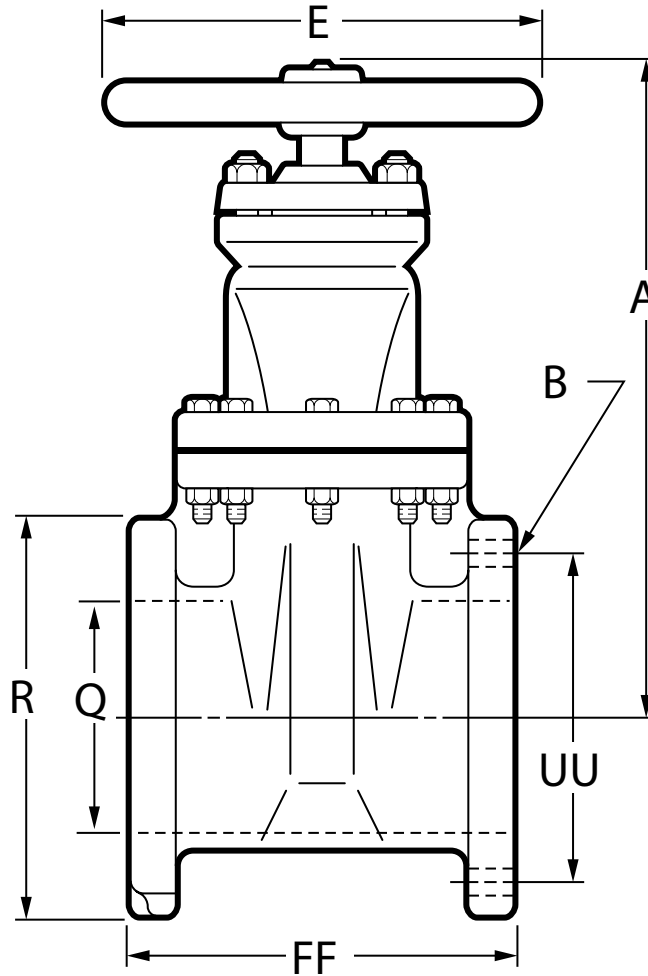

**Dimensions**

Dimension	Nominal Size					
	3"	4"	6"	8"	10"	12"
A	12.38	14.19	18.00	21.50	25.50	28.62
E	8.00	11.00	13.00	14.00	16.00	16.00
R	7.50	9.00	11.00	13.50	16.00	19.00
FF	8.00	9.00	10.50	11.50	13.00	14.00
Q (bore)	3.30	4.30	6.30	8.30	10.30	12.30
UU (bolt circle diameter)	6.00	7.50	9.50	11.75	14.25	17.00
B (number and size of holes)	4--.75	8--.75	8--.88	8--.88	12--1.00	12--1.00
Turns to open	11	14	20.5	26.5	33	38.5
Weight*	73	96	154	250	392	522

\*All dimensions are in inches. All weights are in pounds and are approximate.

Rev. 7-16 Shaded area indicates changes

- Catalog number –
  - A-2362-16** mechanical joint x flanged ends (with accessories unassembled)
  - A-2362-19** mechanical joint x flanged ends (less accessories)
- Sizes – 3", 4", 6", 8", 10", 12"
- Meets or exceeds all applicable requirements of ANSI/AWWA C509 and C515, UL 262 Listed, FM 1120/1130 Approved, and certified to ANSI/NSF 61
- Flanged end drilling complies with ASME/ANSI B16.1 Class 125
- Mechanical joint end complies with ANSI/AWWA C111 Standard
- Iron body with nominal 10 mils MUELLER® Pro-Guard® Fusion Bonded Epoxy Coated interior and exterior surfaces
- Epoxy coating meets or exceeds all applicable requirements of ANSI/AWWA C550 Standard
- Iron wedge, symmetrical and fully encapsulated with molded rubber; no exposed iron
- Non-rising stem (NRS)
- Triple O-ring seal (2 above the thrust collar and 1 below)
- 2" square wrench nut - open left or open right
- 250 psig (1725 kPa/17 barg) maximum working pressure; 500 psig (3450 kPa/35 barg) static test pressure
- UL Listed, FM Approved – 200 psig (1375 kPa/14 barg)
- Mueller valves are designed for potable water applications



**A-2362-16**  
M.J. accessories  
shipped unassembled

### Options

See page 10.46 for more information on Resilient Wedge Gate Valve options

- Position indicators
- ASTM B98-C66100/H02 stem
- Stainless steel stem: Type 304, Type 316
- Handwheel
- EPDM Disc and o-rings
- Stainless steel fasteners: Type 316

### Resilient wedge gate valve parts

Catalog Part No.	Description	Material	Material Standard
G-16	Bonnet Bolts & Nuts	304 Stainless Steel	ASTM F593 (bolt) ASTM F594 (nut)
G-41	Stuffing Box Bolts & Nuts	304 Stainless Steel	ASTM F593 (bolt) ASTM F594 (nut)
G-49	Stem O-rings (3)	Nitrile	ASTM D2000
G-200	Wrench Nut Cap Screw	304 Stainless Steel	ASTM F593
G-201	Stuffing Box O-ring	Nitrile	ASTM D2000
G-202	Wrench Nut	Ductile Iron	ASTMA536 ▼
G-203	Stem	Bronze	ASTM B138
G-204	Hand Wheel (not shown)	Cast Iron +	ASTM A126 CL.B
G-205	Stem Nut	Bronze	ASTM B62
G-206	Guide Cap Bearings	Acetal	-
G-207	Stuffing Box with dirt seal**	Cast Iron + Nitrile	ASTM A126 CL.B ASTM D2000
G-208	Anti-friction Washers (2)	Acetal	-
G-209	Wedge, Rubber Encapsulation	Ductile Iron* SBR	ASTMA536 ▼ ASTM D2000
G-210**	Bonnet	Ductile Iron	ASTMA536 ▼
G-211**	Bonnet gasket	Nitrile	ASTM D2000
G-212**	Body	Ductile Iron	ASTMA536 ▼

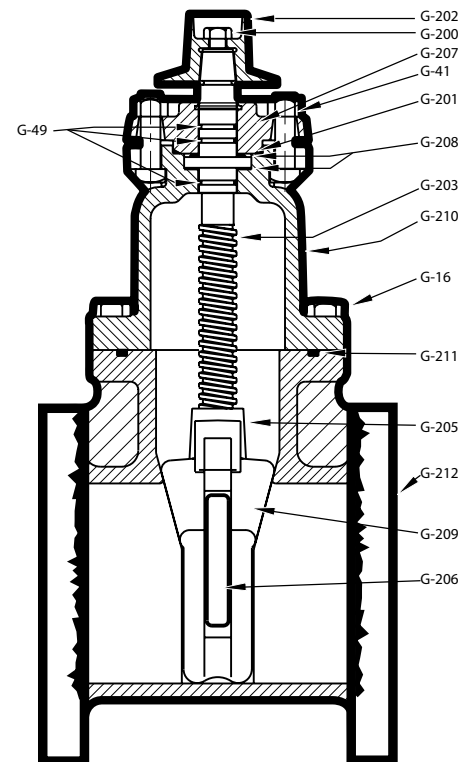

\*Fully encapsulated in molded rubber with no iron exposed

\*\*Dirt seal on 4" - 12" valves

▼ Material strength ASTM A536 65-45 minimum

+ Manufacturer's option to upgrade material to ductile iron ASTM A536

**3" - 12" A-2362 RESILIENT WEDGE  
GATE VALVES - M.J. x FL.**



**10.35**

Shaded area indicates change Rev. 5-15

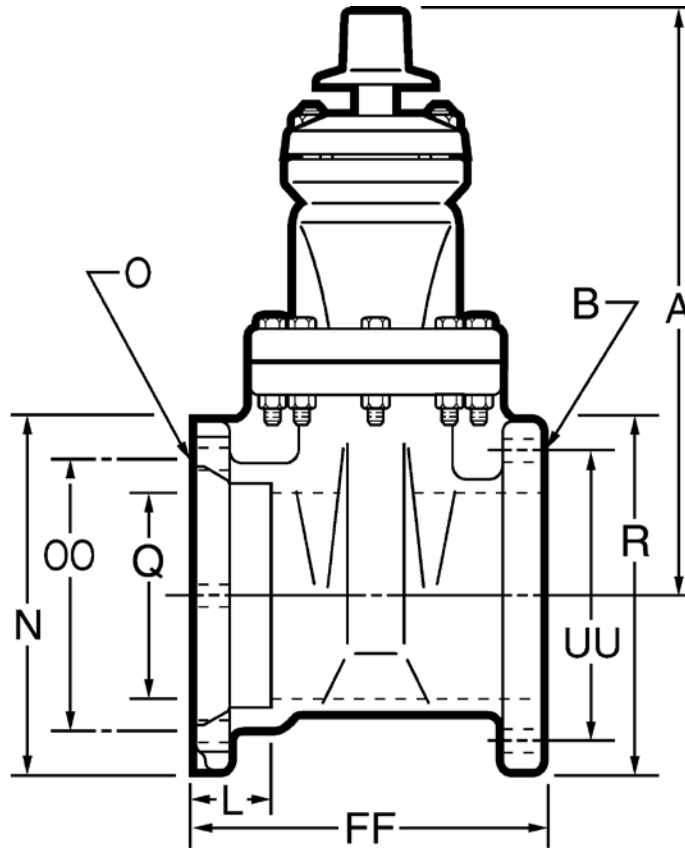

**Dimensions**

Dimension	Nominal Size					
	3"	4"	6"	8"	10"	12"
A	12.38	14.19	18.00	21.50	25.50	28.62
L	2.50	2.50	2.50	2.50	2.50	2.50
N	7.50	9.12	11.12	13.37	15.62	17.88
O	4--.88	4--.88	6--.88	6--.88	8--.88	8--.88
Q (bore)	3.30	4.30	6.30	8.30	10.30	12.30
OO (bolt circle diameter)	6.19	7.50	9.50	11.75	14.00	16.25
R (number and size of holes)	7.50	9.00	11.00	13.50	16.00	19.00
UU	5.50	7.50	9.50	11.75	14.25	17.00
FF	8.8	9.50	11.06	12.09	13.94	14.50
B	4--.75	8--.75	8--.88	8--.88	12--1.00	12--1.00
Turns to open	11	14	20.5	26.5	33	38.5
Weight*	67	115	168	275	400	570

\* All dimensions are in inches. All weights include accessories are in pounds and are approximate.

Rev. 7-16 Shaded area indicates changes

- Catalog number–  
**A-2362-38** Slip-on ends with gasket  
**A-2362-40** Slip-on ends less gasket
- Sizes – 4", 6", 8", 10", 12"
- Meets or exceeds all applicable requirements of ANSI/AWWA C509 and C515, UL 262 Listed, FM 1120/1130 Approved, and certified to ANSI/NSF 61
- Slip-on ends fit plain end of classes 150, 200 and 250 cast iron; ductile iron and classes 150 and 200 cast iron O.D. PVC
- Iron body with nominal 10 mils MUELLER® Pro-Gard® Fusion Bonded Epoxy Coated interior and exterior surfaces
- Epoxy coating meets or exceeds all applicable requirements of ANSI/AWWA C550 Standard
- Iron wedge, symmetrical and fully encapsulated with molded rubber; no exposed iron
- Non-rising stem (NRS)
- Triple O-ring seal (2 above the thrust collar and 1 below)
- 2" square wrench nut - open left or open right
- 250 psig (1725 kPa/17 barg) maximum working pressure; 500 psig (3450 kPa/35 barg) static test pressure
- UL Listed, FM Approved: 200 psig (1375 kPa/14 barg)
- Mueller valves are designed for potable water applications



**A-2362-38**

*Slip-on ends on this valve are not intended for use with Field Lok†† restrained gaskets. Use valve on page 10.13A*

### Options

See page 10.46 for more information on Resilient Wedge Gate Valve options

- Position indicators
- Stainless steel fasteners: Type 316
- Stainless steel stem: Type 304, Type 316
- ASTM B98-C66100/H02 stem
- Handwheel
- EPDM Disc and o-rings

### Resilient wedge gate valve parts

Catalog Part No.	Description	Material	Material Standard
G-16	Bonnet Bolts & Nuts	304 Stainless Steel	ASTM F593 (bolt) ASTM F594 (nut)
G-41	Stuffing Box Bolts & Nuts	304 Stainless Steel	ASTM F593 (bolt) ASTM F594 (nut)
G-49	Stem O-rings (3)	Nitrile	ASTM D2000
G-200	Wrench Nut Cap Screw	304 Stainless Steel	ASTM F593
G-201	Stuffing Box O-ring	Nitrile	ASTM D2000
G-202	Wrench Nut	Ductile Iron	ASTMA536 ▼
G-203	Stem	Bronze	ASTM B138
G-204	Hand Wheel (not shown)	Cast Iron +	ASTM A126 CL.B
G-205	Stem Nut	Bronze	ASTM B62
G-206	Guide Cap Bearings	Acetal	-
G-207	Stuffing Box with dirt seal	Cast Iron + Nitrile	ASTM A126 CL.B ASTM D2000
G-208	Anti-friction Washers (2)	Acetal	-
G-209	Wedge, Rubber Encapsulation	Ductile Iron SBR*	ASTM A536 ▼ ASTM D2000
G-210**	Bonnet	Ductile Iron	ASTMA536 ▼
G-211**	Bonnet O-ring	Nitrile	ASTM D2000
G-212**	Body	Ductile Iron	ASTMA536 ▼

\*Fully encapsulated in molded rubber with no iron exposed

▼ Material strength ASTM A536 65-45 minimum

+ Manufacturer's option to upgrade material to ductile iron ASTM A536

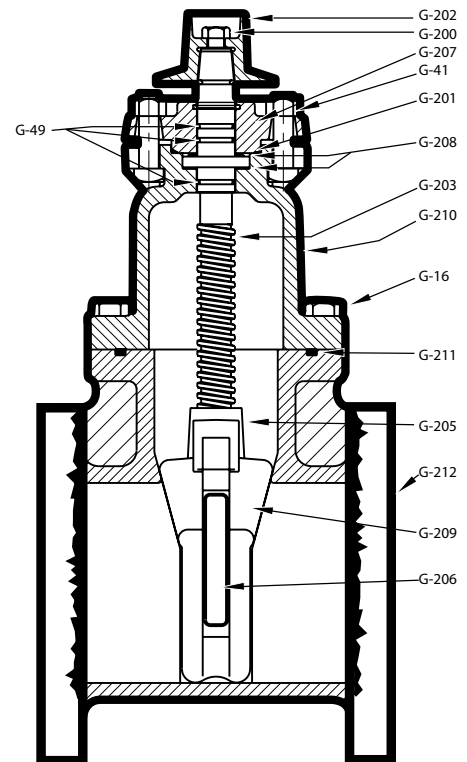



**4" - 12" A-2362 RESILIENT WEDGE  
GATE VALVES - SL. x SL.**



**10.37**

Shaded area indicates change Rev. 1-15

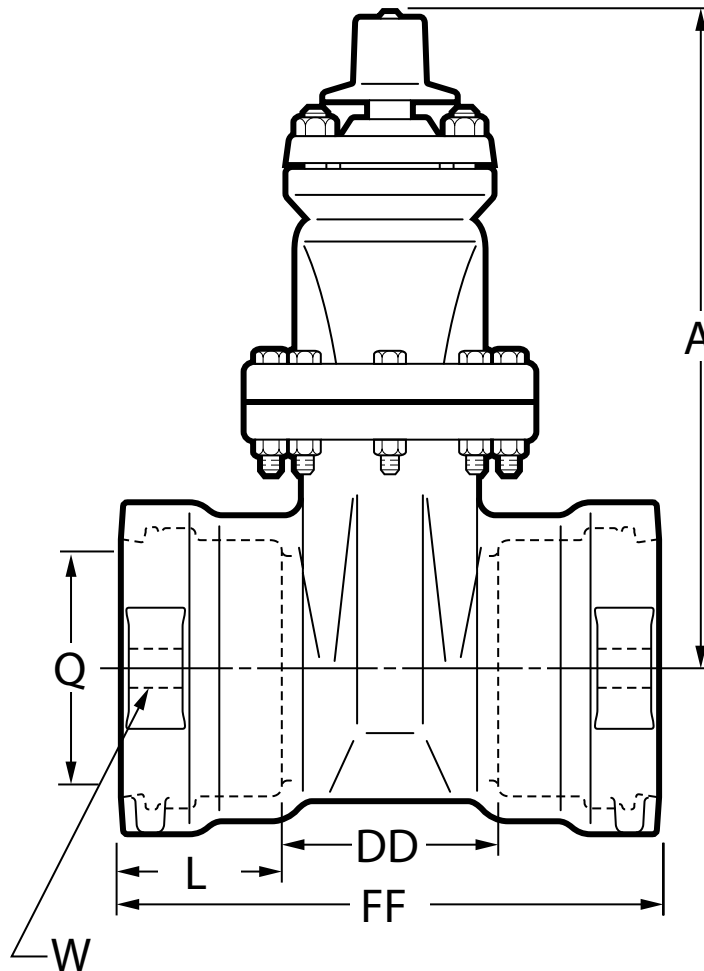

**Dimensions**

Dimension	Nominal Size				
	4"	6"	8"	10"	12"
A	14.19	18.00	21.50	25.50	28.62
Q (bore)	4.30	6.30	8.30	10.30	12.30
W (distance between strapping lug holes across face of valve ends)	8.62	10.62	13.12	16.38	18.12
FF	12.81	14.96	17.94	18.50	18.70
L	4.12	4.38	5.62	5.62	5.62
DD	4.57	6.20	6.70	7.26	7.46
Turns to open	14	20.5	26.5	33	38.5
Weight*	90	156	252	400	565

\*All dimensions are in inches. All weights are in pounds and are approximate.

Rev. 7-16 Shaded area indicates changes

- Catalog number–  
**A-2362-41** Slip-on end (with gasket) x flange end  
**A-2362-43** Slip-on end (less gasket) x flange end
- Sizes – 4", 6", 8", 10", 12"
- Meets or exceeds all applicable requirements of ANSI/AWWA C509 and C515, UL 262 Listed, FM 1120/1130 Approved, and certified to ANSI/NSF 61
- Slip-on ends fit plain end of classes 150, 200 and 250 cast iron, ductile iron and classes 150 and 200 cast iron O.D. PVC
- Flange end drilling complies with ASME/ANSI B16.1 Class 125
- Iron body with nominal 10 mils MUELLER® Pro-Gard® Fusion Bonded Epoxy Coated interior and exterior surfaces
- Epoxy coating meets or exceeds all applicable requirements of ANSI/AWWA C550 Standard
- Iron wedge, symmetrical and fully encapsulated with molded rubber; no exposed iron
- Non-rising stem (NRS)
- Triple O-ring seal (2 above the thrust collar and 1 below)
- 2" square wrench nut - open left or open right
- 250 psig (1725 kPa/17 barg) maximum working pressure; 500 psig (3450 kPa/35 barg) static test pressure
- UL Listed, FM Approved: 200 psig (1375 kPa/14 barg)
- Mueller valves are designed for potable water applications



**A-2362-41**

*Slip-on end on this valve is not intended for use with Field Lok†† restrained gaskets. Use valve on page 10.13C*

††Field Lok is a trademark of U.S. Pipe and Foundry Company, used with permission.

### Options

See page 10.46 for more information on Resilient Wedge Gate Valve options

- Position indicators
- Stainless steel fasteners: Type 316
- Stainless steel stem: Type 304, Type 316
- ASTM B98-C66100/H02 stem
- Handwheel
- EPDM Disc and o-rings

### Resilient wedge gate valve parts

Catalog Part No.	Description	Material	Material Standard
G-16	Bonnet Bolts & Nuts	304 Stainless Steel	ASTM F593 (bolt) ASTM F594 (nut)
G-41	Stuffing Box Bolts & Nuts	304 Stainless Steel	ASTM F593 (bolt) ASTM F594 (nut)
G-49	Stem O-rings (3)	Nitrile	ASTM D2000
G-200	Wrench Nut Cap Screw	304 Stainless Steel	ASTM F593
G-201	Stuffing Box O-ring	Nitrile	ASTM D2000
G-202	Wrench Nut	Ductile Iron	ASTMA536 ▼
G-203	Stem	Bronze	ASTM B138
G-204	Hand Wheel (not shown)	Cast Iron +	ASTMA126 CL.B
G-205	Stem Nut	Bronze	ASTM B62
G-206	Guide Cap Bearings	Acetal	-
G-207	Stuffing Box with dirt seal	Cast Iron + Nitrile	ASTMA126 CL.B ASTM D2000
G-208	Anti-friction Washers (2)	Acetal	-
G-209	Wedge, Rubber Encapsulation	Ductile Iron* SBR	ASTMA536 ▼ ASTM D2000
G-210**	Bonnet	Ductile Iron	ASTMA536 ▼
G-211**	Bonnet O-ring	Nitrile	ASTM D2000
G-212**	Body	Ductile Iron	ASTMA536 ▼

\*Fully encapsulated in molded rubber with no iron exposed

▼ Material strength ASTM A536 65-45 minimum

+ Manufacturer's option to upgrade material to ductile iron ASTM A536

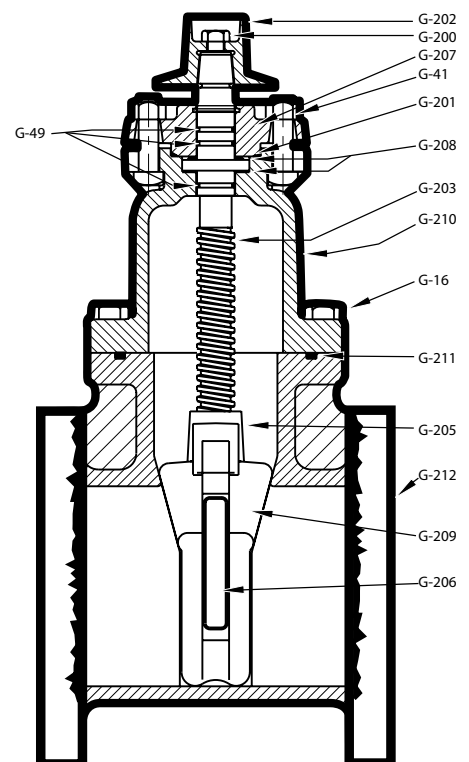

**4" - 12" A-2362 RESILIENT WEDGE  
GATE VALVES - SL. x FL.**



**10.39**

Shaded area indicates change Rev. 1-15

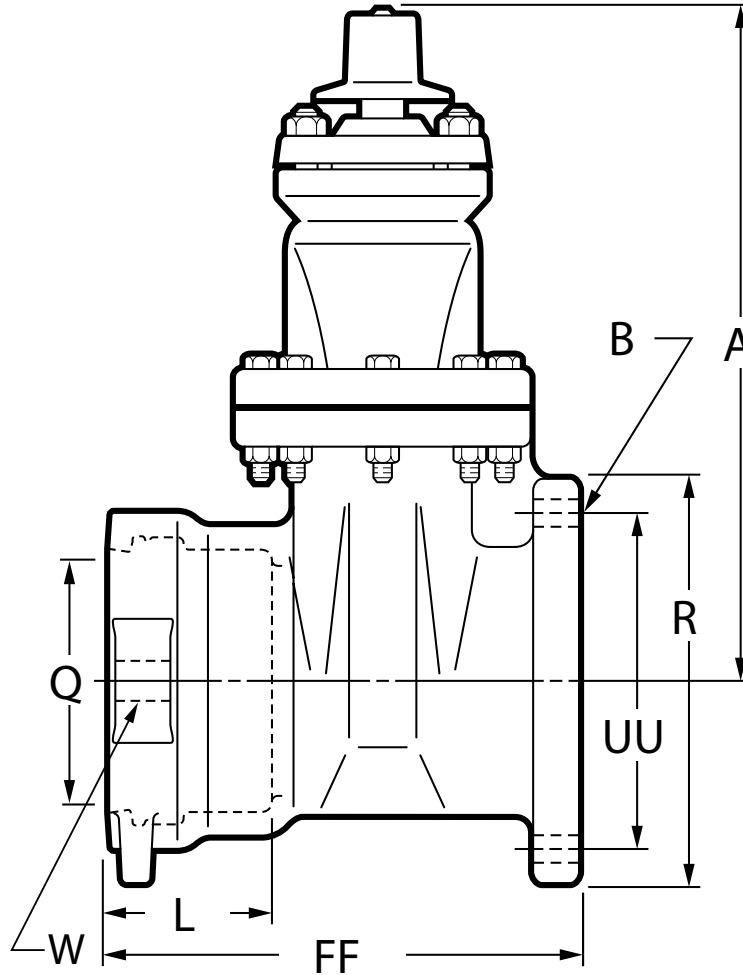

**Dimensions**

Dimension	Nominal Size				
	4"	6"	8"	10"	12"
A	14.19	18.00	21.50	25.50	28.62
Q (bore)	4.30	6.30	8.30	10.30	12.30
L	4.12	4.38	5.62	5.62	5.62
R	9.00	11.00	13.50	16.00	19.00
UU (bolt circle diameter for FL)	7.50	9.50	11.75	14.25	17.00
B (number and size of holes for FL)	8--.75	8--.88	8--.88	12--1.00	12--1.00
W (distance between strapping lug holes across face of valve ends)	8.62	10.62	13.12	16.38	18.12
FF	10.91	12.73	14.72	15.75	16.35
Turns to open	14	20.5	26.5	33	38.5
Weight*	98	152	260	400	565

\*All dimensions are in inches. All weights are in pounds and are approximate.

Rev. 7-16 Shaded area indicates changes

- Catalog number—  
**A-2362-61** Slip On ends (less Field Lok gaskets)
- Sizes – 4", 6", 8", 12"
- Meets or exceeds all applicable requirements of ANSI/AWWA C509 and C515, UL 262 Listed, FM 1120/1130 Approved, and certified to ANSI/NSF 61
- Slip-on ends with Field Lok gaskets are to be used on ductile iron pipe
- Iron body with nominal 10 mils MUELLER® Pro-Gard® Fusion Bonded Epoxy Coated interior and exterior surfaces
- Epoxy coating meets or exceeds all applicable requirements of ANSI/AWWA C550 Standard
- Iron wedge, symmetrical and fully encapsulated with molded rubber; no exposed iron
- Non-rising stem (NRS)
- Triple O-ring seal (2 above the thrust collar and 1 below)
- 2" square wrench nut - open left or open right
- 250 psig (1725 kPa/17 barg) maximum working pressure; 500 psig (3450 kPa/35 barg) static test pressure
- UL Listed, FM Approved: 200 psig (1375 kPa/14 barg)
- Mueller valves are designed for potable water applications



**A-2362-61**

Slip-on ends on this valve are intended for use with Field Lok†† restrained gaskets.

†Design and dimensions of the joint are manufactured under license of U.S. Pipe and Foundry Company.  
 ††Field Lok is a trademark of U.S. Pipe and Foundry Company, used with permission.

### Options

See page 10.46 for more information on Resilient Wedge Gate Valve options

- Position indicators
- Stainless steel fasteners: Type 316
- Stainless steel stem: Type 304, Type 316
- ASTM B98-C66100/H02 stem
- Handwheel
- EPDM Disc and o-rings

### Resilient wedge gate valve parts

Catalog Part No.	Description	Material	Material Standard
G-16	Bonnet Bolts & Nuts	304 Stainless Steel	ASTM F593 (bolt) ASTM F594 (nut)
G-41	Stuffing Box Bolts & Nuts	304 Stainless Steel	ASTM F593 (bolt) ASTM F594 (nut)
G-49	Stem O-rings (3)	Nitrile	ASTM D2000
G-200	Wrench Nut Cap Screw	304 Stainless Steel	ASTM F593
G-201	Stuffing Box O-ring	Nitrile	ASTM D2000
G-202	Wrench Nut	Ductile Iron	ASTMA536 ▼
G-203	Stem	Bronze	ASTM B138
G-204	Hand Wheel (not shown)	Cast Iron +	ASTMA126 CL.B
G-205	Stem Nut	Bronze	ASTM B62
G-206	Guide Cap Bearings	Acetal	-
G-207	Stuffing Box with dirt seal	Cast Iron + Nitrile	ASTMA126 CL.B ASTM D2000
G-208	Anti-friction Washers (2)	Acetal	-
G-209	Wedge, Rubber Encapsulation	Ductile Iron* SBR	ASTMA536 ▼ ASTM D2000
G-210**	Bonnet	Ductile Iron	ASTMA536 ▼
G-211**	Bonnet O-ring	Nitrile	ASTM D2000
G-212**	Body	Ductile Iron	ASTMA536 ▼

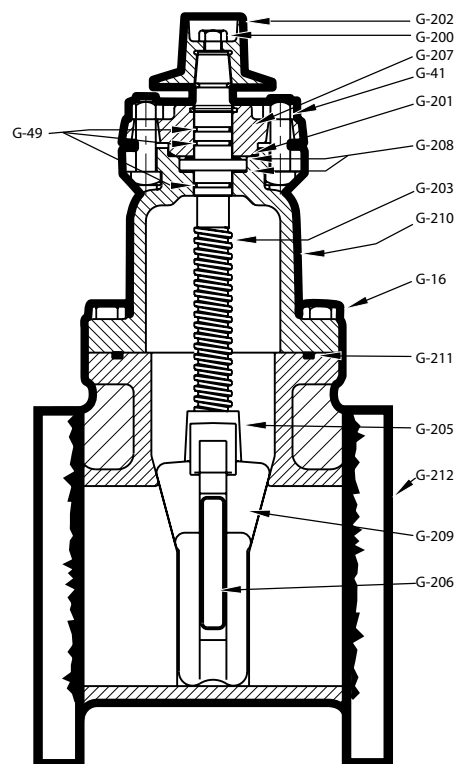

\*Fully encapsulated in molded rubber with no iron exposed  
 ▼ Material strength ASTM A536 65-45 minimum  
 + Manufacturer's option to upgrade material to ductile iron ASTM A536

**4" - 12" A-2362 RESILIENT WEDGE GATE  
VALVES - SL. x SL. (FOR FIELD LOK™\*\* GASKETS)**



**10.41**

Shaded area indicates change Rev. 1-15

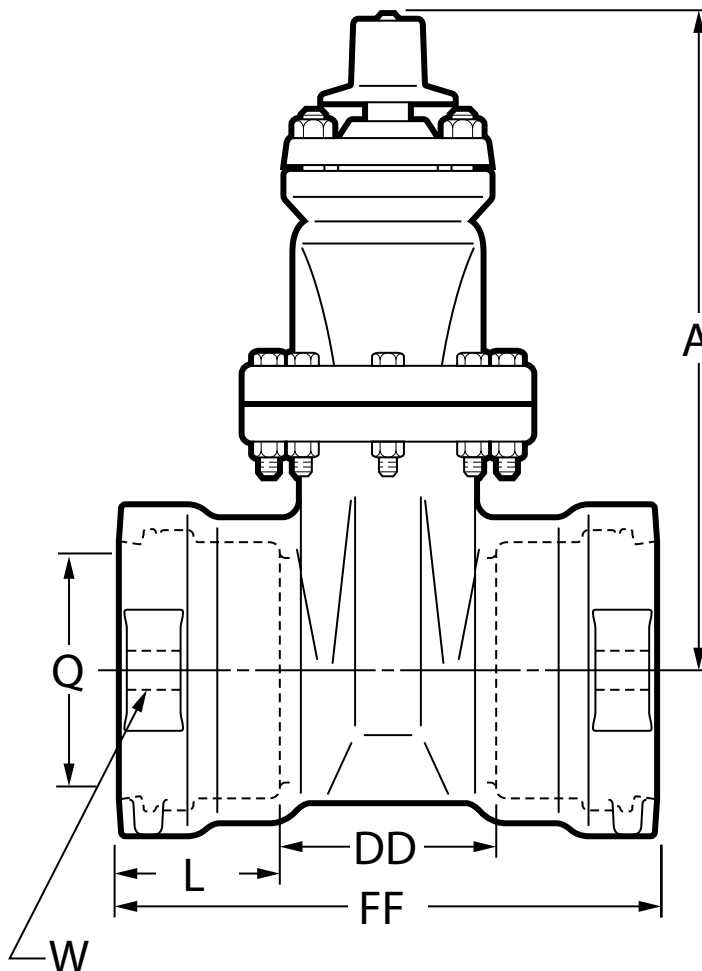

**Dimensions**

Dimension	Nominal Size				
	4"	6"	8"	10"	12"
A	14.19	18.00	21.50	25.50	28.62
Q (bore)	4.30	6.30	8.30	10.30	12.30
W (distance between strapping lug holes across face of valve ends)	8.62	10.62	13.12	16.38	18.12
FF	12.81	14.96	17.94	18.50	18.70
L	4.12	4.38	5.62	5.62	5.62
DD	4.57	6.2	6.7	7.26	7.46
Turns to open	14	20.5	26.5	33	38.5
Weight*	90	165	260	400	565

\*All dimensions are in inches. All weights are in pounds and are approximate.

\*\*Field Lok is a trademark of U.S. Pipe and Foundry Company, used with permission.

Rev. 7-16 Shaded area indicates changes

- Catalog number–  
**A-2362-62** Slip On (less Field Lok gasket) x flange end
- Sizes – 4", 6", 8", 12"
- Meets or exceeds all applicable requirements of ANSI/AWWA C509 and C515, UL 262 Listed, FM 1120/1130 Approved, and certified to ANSI/NSF 61
- Slip-on ends with Field Lok gaskets are to be used on ductile iron pipe
- Flange end drilling complies with ASME/ANSI B16.1 Class 125
- Iron body with nominal 10 mils MUELLER® Pro-Gard® Fusion Bonded Epoxy Coated interior and exterior surfaces
- Epoxy coating meets or exceeds all applicable requirements of ANSI/AWWA C550 Standard
- Iron wedge, symmetrical and fully encapsulated with molded rubber; no exposed iron
- Non-rising stem (NRS)
- Triple O-ring seal (2 above the thrust collar and 1 below)
- 2" square wrench nut - open left or open right
- 250 psig (1725 kPa/17 barg) maximum working pressure; 500 psig (3450 kPa/35 barg) static test pressure
- UL Listed, FM Approved: 200 psig (1375 kPa/14 barg)
- Mueller valves are designed for potable water applications



**A-2362-62**

Slip-on end on this valve is intended for use with Field Lok†† restrained gaskets.

†Design and dimensions of the joint are manufactured under license of U.S. Pipe and Foundry Company.  
††Field Lok is a trademark of U.S. Pipe and Foundry Company, used with permission.

### Options

See page 10.46 for more information on Resilient Wedge Gate Valve options

- Position indicators
- Stainless steel fasteners: Type 316
- Stainless steel stem: Type 304, Type 316
- ASTM B98-C66100/H02 stem
- Handwheel
- EPDM Disc and o-rings

### Resilient wedge gate valve parts

Catalog Part No.	Description	Material	Material Standard
G-16	Bonnet Bolts & Nuts	304 Stainless Steel	ASTM F593 (bolt) ASTM F594 (nut)
G-41	Stuffing Box Bolts & Nuts	304 Stainless Steel	ASTM F593 (bolt) ASTM F594 (nut)
G-49	Stem O-rings (3)	Nitrile	ASTM D2000
G-200	Wrench Nut Cap Screw	304 Stainless Steel	ASTM F593
G-201	Stuffing Box O-ring	Nitrile	ASTM D2000
G-202	Wrench Nut	Ductile Iron	ASTMA536 ▼
G-203	Stem	Bronze	ASTM B138
G-204	Hand Wheel (not shown)	Cast Iron +	ASTM A126 CL.B
G-205	Stem Nut	Bronze	ASTM B62
G-206	Guide Cap Bearings	Acetal	-
G-207	Stuffing Box with dirt seal	Cast Iron + Nitrile	ASTM A126 CL.B ASTM D2000
G-208	Anti-friction Washers (2)	Acetal	-
G-209	Wedge, Rubber Encapsulation	Ductile Iron* SBR	AASTMA536 ▼ ASTM D2000
G-210**	Bonnet	Ductile Iron	ASTMA536 ▼
G-211**	Bonnet O-ring	Nitrile	ASTM D2000
G-212**	Body	Ductile Iron	ASTMA536 ▼

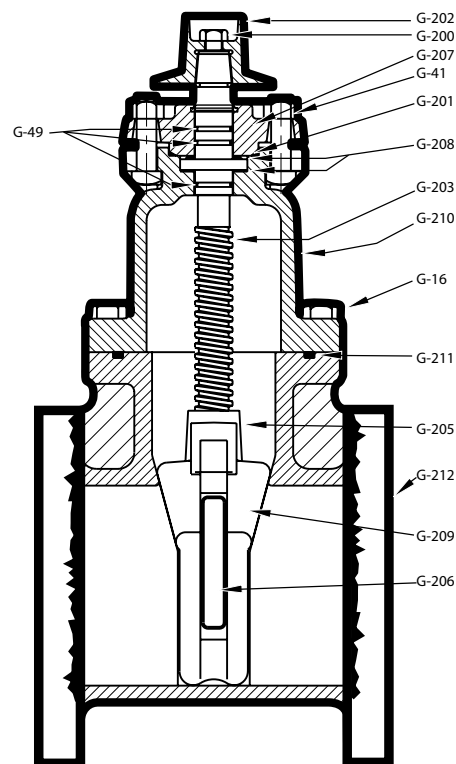

\*Fully encapsulated in molded rubber with no iron exposed

▼ Material strength ASTM A536 65-45 minimum

+ Manufacturer's option to upgrade material to ductile iron ASTM A536

**4" - 12" A-2362 RESILIENT WEDGE GATE  
VALVES - SL. x FL. (FOR FIELD LOK™\*\* GASKETS)**



**10.43**

Shaded area indicates change Rev. 1-15

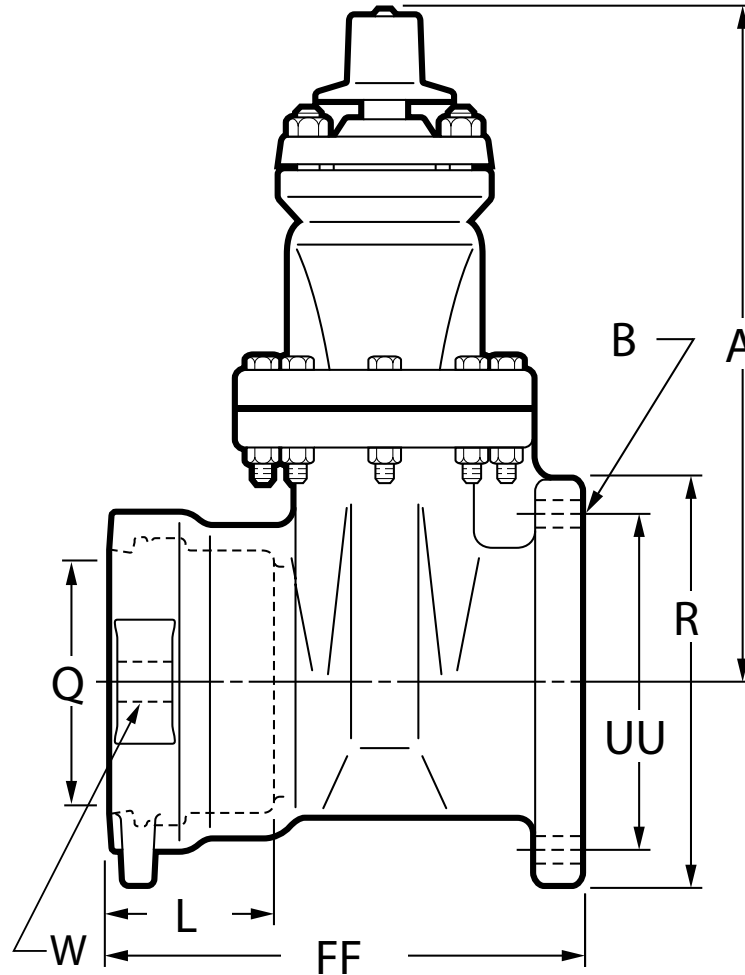

**Dimensions**

Dimension	Nominal Size				
	4"	6"	8"	10"	12"
A	14.19	18.00	21.50	25.50	28.62
Q (bore)	4.30	6.30	8.30	10.30	12.30
L	4.12	4.38	5.62	5.62	5.62
R	9.00	11.00	13.50	16.00	19.00
UU (bolt circle diameter for FL)	7.50	9.50	11.75	14.25	17.00
B (number and size of holes for FL)	8--.75	8--.88	8--.88	12--1.00	12--1.00
W (distance between strapping lug holes across face of valve ends)	8.62	10.62	13.12	16.38	18.12
FF	10.91	12.73	14.72	15.75	16.35
Turns to open	14	20.5	26.5	33	38.5
Weight*	98	152	260	400	565

\*All dimensions are in inches. All weights are in pounds and are approximate.

\*\*Field Lok is a trademark of U.S. Pipe and Foundry Company, used with permission.

Rev. 7-16 Shaded area indicates changes

- Catalog number–  
**A-2380-6** flanged ends
- Sizes – 14", 16", 18", 20", 24", 30", 36"
- Meets or exceeds all applicable requirements of ANSI/AWWA C500 Standard
- Flange ends comply with ASME/ANSI B16.1 Class 125
- Iron body - bronze mounted
- Double disc parallel seat with four point wedging mechanism
- Non-rising stem (NRS)
- O-ring sealed stuffing box
- With handwheel - open left or open right
- 150 psig (1000 kPa/10 barg) maximum working pressure; 300 psig (2100 kPa/21 barg) test pressure
- Mueller valves are designed for potable water applications



**A-2380-6**

### Options

See pages 10.46 for more information on Gate Valve options.

- ASTM B98-C66100/H02 stem and disc pins ASTM B763-C99500 Stem 18" - 36"
- Bevel gearing
- Spur gearing
- Roller, track, scrapers; 16" - 36"
- Position indicators (14"-16" only)
- NRS by-pass valve
- 2" Square wrench nut
- Epoxy Coating
- Stainless steel fasteners: Type 304 or Type 316

### Double-disc gate valve parts

Catalog Part No.	Description	Material	Material Standard
G-15	Bonnet gasket	Composition	ASTM D1170
G-16	Bonnet Bolts & Nuts	Steel	SAE J429 Grade 2 (bolt) ASTM A563 Grade A (nut)
G-18	Seat ring	Bronze	ASTM B62
G-19	Disc and disc ring	Cast Iron*	ASTM A126 CL.B
G-20	Disc pin	Bronze	ASTM B21
G-21	Side spreader	Bronze	ASTM B62
G-22	Bottom wedge	Cast Iron	ASTM A126 CL.B
G-24	Test plug	Iron	-
G-26	Nut for wrench nut	Steel	ASTM A563 Grade A
G-32	Stuffing box gasket	Fiber	-
G-37	Top wedge nut	Cast Iron*	ASTM A126 CL.B
G-38	Wrench nut	Cast Iron	ASTM A126 CL.B
G-41	Stuffing box bolt and nut	Steel	SAE J429 Grade 2 (bolt) ASTM A563 Grade A (nut)
G-42	Stem	Bronze	ASTM B138**
G-43	Bonnet	Cast Iron	ASTM A126 CL.B
G-45	Hand wheel	Cast Iron	ASTM A126 CL.B
G-47	Body	Cast Iron	ASTM A126 CL.B
G-48	Stuffing box o-ring	Rubber	ASTM D2000
G-49	Stem o-ring	Rubber	ASTM D2000
G-50	Stuffing box	Cast Iron	ASTM A126 CL.B

\* Cast iron discs with rolled-in bronze facings; cast iron top wedge nut with integrally cast bronze bushing.

\*\*18" - 36" ASTM B584

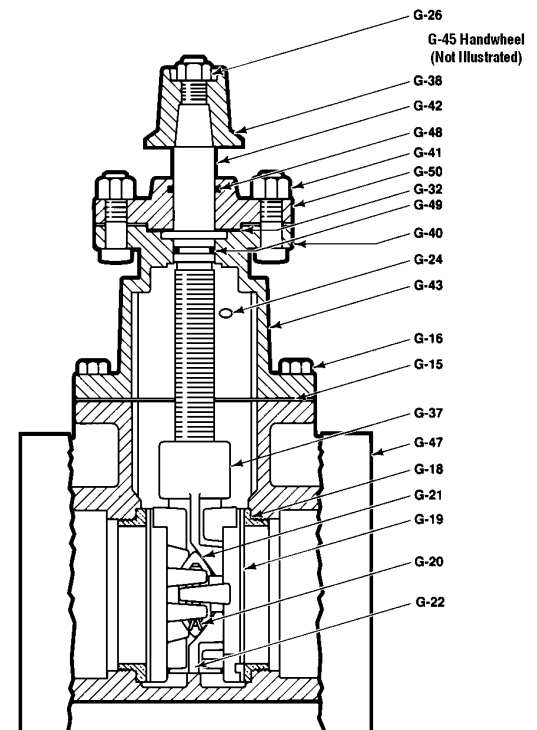



**14" - 36" DOUBLE-DISC NRS  
GATE VALVES - FL. x FL.**



**10.45**

Shaded area indicates change Rev. 4-14

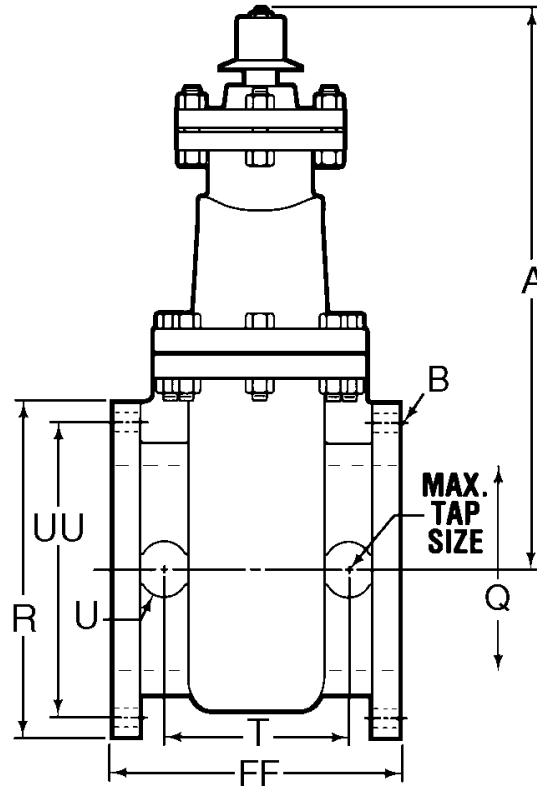

**Dimensions**

Dimension*	Nominal Size						
	14"	16"	18"	20"	24"	30"	36"
A	34.12	39.00	43.00	47.50	55.75	66.50	**
Q (bore)	14.00	16.00	18.00	20.00	24.00	30.00	36.00
FF	15.00	20.25	22.00	22.25	25.50	28.75	32.00
R	21.00	23.50	25.00	27.50	32.00	38.75	46.00
T	9.00	N/A	N/A	N/A	N/A	N/A	N/A
U	3.00	N/A	N/A	N/A	N/A	N/A	N/A
UU (bolt circle diameter)	18.75	21.25	22.75	25.00	29.50	36.00	42.75
B (number and size of holes)	12-1-1/8	16--1-1/8	16--1-1/4	20--1-1/4	20--1-3/8	28--1-3/8	32--1-5/8
Maximum tap size	2	N/A	N/A	N/A	N/A	N/A	N/A
Turns to open	46	53	59	65	77	65	78
Weight*	747	1156	1439	1775	2943	5189	8061

\*All dimensions are in inches. All weights are in pounds and are approximate.

\*\*36" valves sold only with gear operators, dimension depends on style of operator selected. Contact Customer Service for Dimension.

Rev. 7-16 Shaded area indicates changes

- Catalog number–  
**A-2380-16** flanged x mechanical joint (with accessories unassembled)  
**A-2380-18** flanged x mechanical joint (accessories and bonding set screws in gland unassembled)  
**A-2380-19** flanged x mechanical joint (less accessories)
- Sizes - 30" & 36"
- Meets or exceeds all applicable requirements of ANSI/AWWA C500 Standard
- Flange ends comply with ASME/ANSI B16.1 Class 125
- Mechanical joint ends comply with ANSI/AWWA C111 Standard
- Iron body - bronze mounted
- Double disc parallel seat with four point wedging mechanism
- Non-rising stem (NRS)
- O-ring sealed stuffing box
- 2" square wrench nut - open left or open right
- 150 psig (1000 kPa/10 barg) maximum working pressure; 300 psig (2100 kPa/21 barg) test pressure
- Mueller valves are designed for potable water applications

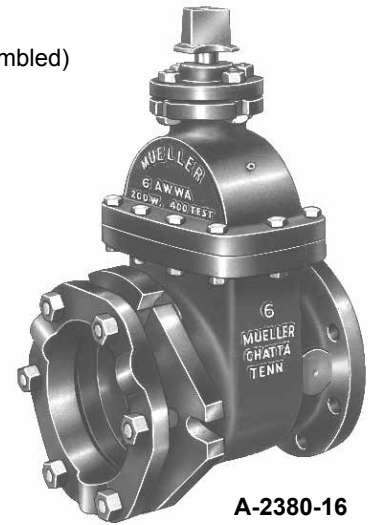

**A-2380-16**

### Options

See pages 10.46 for more information on Gate Valve options.

- ASTM B98-C66100/H02 disc pins ASTM B763-C99500 stem
- Bevel gearing     Roller, track, scrapers; 16" - 36"     Stainless steel fasteners: Type 304 or Type 316
- Spur gearing     NRS by-pass valve     Epoxy Coating     Handwheel

### Double-disc gate valve parts

Catalog Part No.	Description	Material	Material Standard
G-15	Bonnet gasket	Composition	ASTM D1170
G-16	Bonnet Bolts & Nuts	Steel	SAE J429 Grade 2 (bolt) ASTM A563 Grade A (nut)
G-18	Seat ring	Bronze	ASTM B62
G-19	Disc and disc ring	Cast Iron*	ASTM A126 CL.B
G-20	Disc pin	Bronze	ASTM B21
G-21	Side spreader	Bronze	ASTM B62
G-22	Bottom wedge	Cast Iron	ASTM A126 CL.B
G-24	Test plug	Steel	ANSI 1008-1010
G-26	Nut for wrench nut	Steel	ASTM A563 Grade A
G-32	Stuffing box gasket	Fiber	-
G-37	Top wedge nut	Cast Iron*	ASTM A126 CL.B
G-38	Wrench nut	Cast Iron	ASTM A126 CL.B
G-41	Stuffing box bolt and nut	Steel	SAE J429 Grade 2 (bolt) ASTM A563 Grade A (nut)
G-42	Stem	Bronze	ASTM B584
G-43	Bonnet	Cast Iron	ASTM A126 CL.B
G-45	Hand wheel	Cast Iron	ASTM A126 CL.B
G-47	Body	Cast Iron	ASTM A126 CL.B
G-48	Stuffing box o-ring	Rubber	ASTM D2000
G-49	Stem o-ring	Rubber	ASTM D2000
G-50	Stuffing box	Cast Iron	ASTM A126 CL.B

\*\* Cast iron discs with rolled-in bronze facings; cast iron top wedge nut with integrally cast bronze bushing.

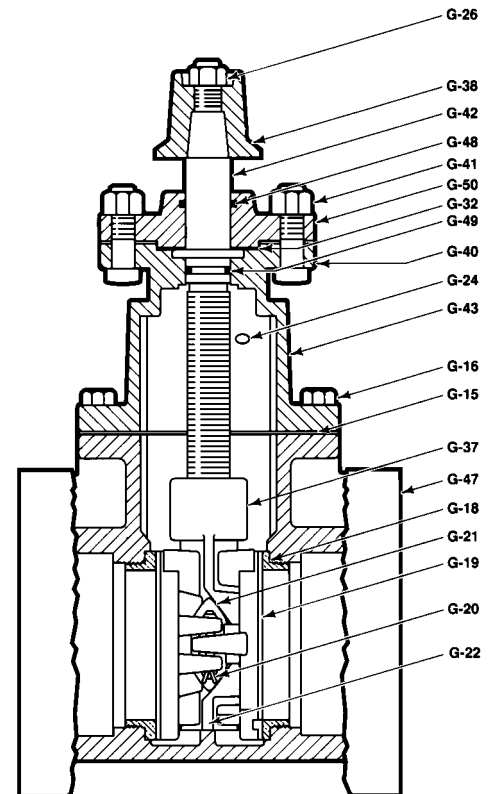

**30" & 36" DOUBLE-DISC NRS  
GATE VALVES - STANDARD FL. x M.J.**



**10.47**

Shaded area indicates change Rev. 4-14

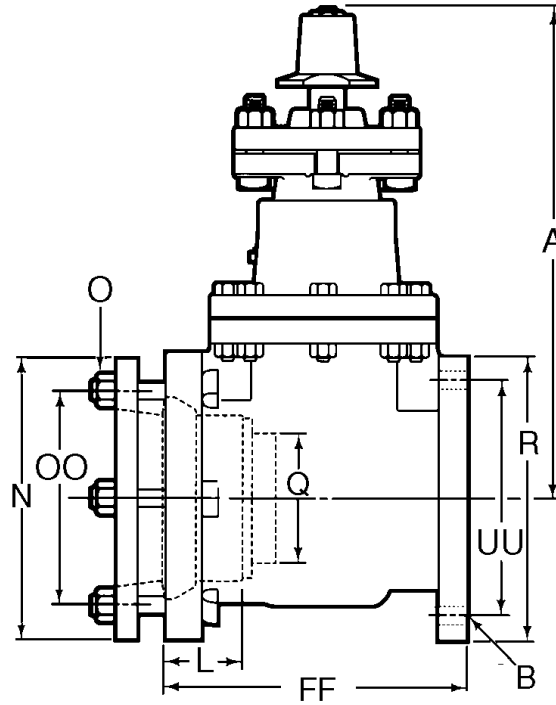

**Dimensions**

Dimension	Nominal Size	
	30"	36"
A	66.50	**
L	4.00	4.00
N	39.12	46.00
OO (bolt circle diameter)	36.88	43.75
Q (bore)	30.00	36.00
R	38.75	46.00
UU	36.00	42.75
XX	24.38	27.50
FF	28.38	31.50
B (number and size of holes for FL)	28--1-3/8	32--1-5/8
O (number and size of holes for MJ)	20--1-1/8	24--1-1/8
Turns to open	65	78
Weight*	5100	8300

\*All dimensions are in inches. All weights are in pounds and are approximate.

\*\*36" valves sold only with gear operators, dimension depends on style of operator selected. Contact Customer Service for Dimension.

Rev. 7-16 Shaded area indicates changes

- Catalog number–  
**A-2380-20** standard mechanical joint ends (with accessories unassembled)  
**A-2380-23** standard mechanical joint ends (less accessories)
- Sizes - 14", 16", 18", 20", 24", 30", 36"
- Meets or exceeds all applicable requirements of ANSI/AWWA C500 Standard
- Mechanical joint ends comply with ASME/ANSI/AWWA C111 Standard
- Iron body - bronze mounted
- Double disc parallel seat with four point wedging mechanism
- Non-rising stem (NRS)
- O-ring sealed stuffing box
- 2" square wrench nut - open left or open right
- 150 psig (1000 kPa/10 barg) maximum working pressure; 300 psig (2100 kPa/21 barg) test pressure
- Mueller valves are designed for potable water applications



**A-2380-20**

### Options

See pages 10.46 for more information on Gate Valve options.

- ASTM B98-C66100/H02 stem and disc pins ASTM B763-C99500 Stem 18" - 36"
- Bevel gearing  Roller, track, scrapers; 16" - 36"
- NRS by-pass valve  Stainless steel fasteners: Type 304 and Type 316
- Spur gearing
- Position indicators (14" - 16" only)
- Epoxy Coating
- Handwheel

### Double-disc gate valve parts

Catalog Part No.	Description	Material	Material Standard
G-15	Bonnet gasket	Composition	ASTM D1170
G-16	Bonnet Bolts & Nuts	Steel	SAE J429 Grade 2 (bolt) ASTM A563 Grade A (nut)
G-18	Seat ring	Bronze	ASTM B62
G-19	Disc and disc ring	Cast Iron*	ASTM A126 CL.B
G-20	Disc pin	Bronze	ASTM B21
G-21	Side spreader	Bronze	ASTM B62
G-22	Bottom wedge	Cast Iron	ASTM A126 CL.B
G-24	Test plug	Steel	ANSI 1008-1010
G-26	Nut for wrench nut	Steel	ASTM A563 Grade A
G-32	Stuffing box gasket	Fiber	-
G-37	Top wedge nut	Cast Iron*	ASTM A126 CL.B
G-38	Wrench nut	Cast Iron	ASTM A126 CL.B
G-41	Stuffing box bolt and nut	Steel	SAE J429 Grade 2 (bolt) ASTM A563 Grade A (nut)
G-42	Stem	Bronze	ASTM B138***
G-43	Bonnet	Cast Iron	ASTM A126 CL.B
G-45	Hand wheel	Cast Iron	ASTM A126 CL.B
G-47	Body	Cast Iron	ASTM A126 CL.B
G-48	Stuffing box o-ring	Rubber	ASTM D2000
G-49	Stem o-ring	Rubber	ASTM D2000
G-50	Stuffing box	Cast Iron	ASTM A126 CL.B

\*\* Cast iron discs with rolled-in bronze facings; cast iron top wedge nut with integrally cast bronze bushing.  
\*\*\*18" - 36" ASTM B583

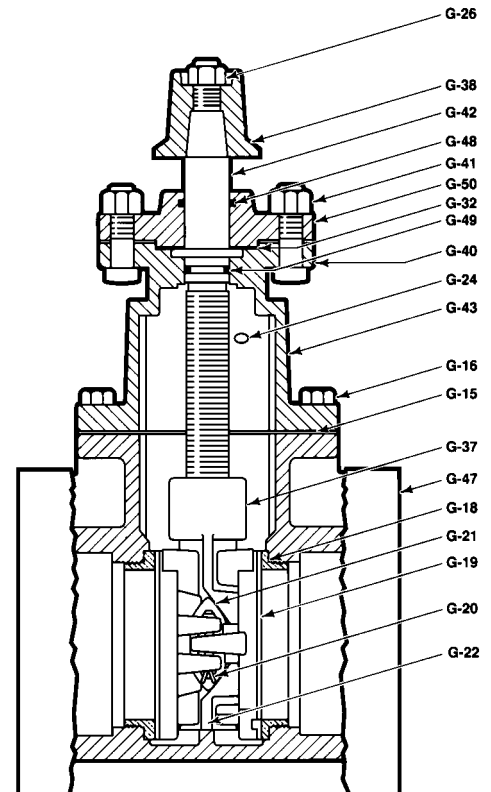

**14" - 36" DOUBLE-DISC NRS  
GATE VALVES - STANDARD M.J. x M.J.**



**10.49**

Shaded area indicates change Rev. 4-14

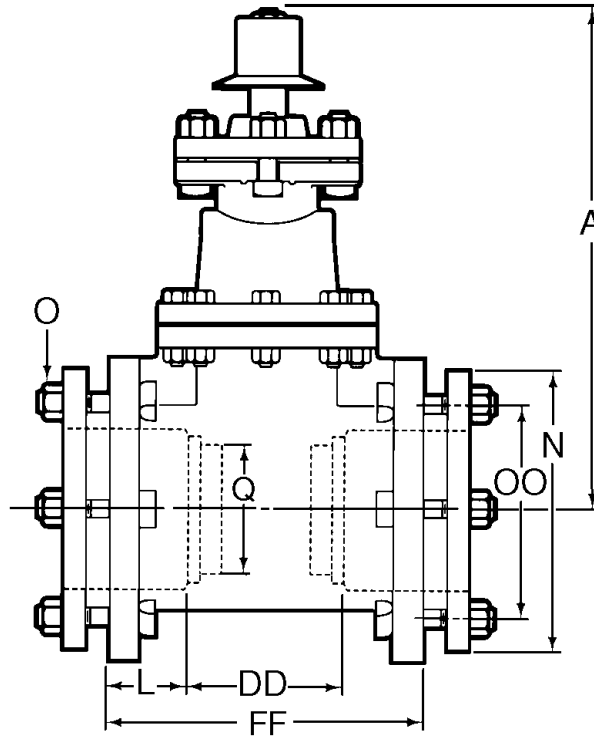

**Dimensions**

Dimension*	Nominal Size						
	14"	16"	18"	20"	24"	30"	36"
A	34.12	39.00	43.00	47.50	55.75	66.50	**
FF	15.00	19.75	21.00	21.50	23.50	28.00	31.00
L	3.50	3.50	3.50	3.50	3.50	4.00	4.00
N	20.31	22.56	24.83	27.08	31.58	39.12	46.00
O (number and size of holes)	10--7/8	12--7/8	12--7/8	14--7/8	16--7/8	20--1-1/8	24--1-1/8
DD	8.00	12.75	14.00	14.50	16.50	20.00	23.00
Q (bore)	14.00	16.00	18.00	20.00	24.00	30.00	36.00
OO (bolt circle diameter)	18.75	21.00	23.25	25.50	30.00	36.88	43.75
Turns to open	46	53	59	65	77	65	78
Weight*	805	1108	1488	1810	2605	5100	8300

Rev. 7-16 Shaded area indicates changes

### Resilient Wedge Options

#### Clean out Port Option on 24"-54" RWGV

Cleanout port option is available for 24"- 54" resilient wedge gate valves. 24" valves would utilize a 1-1/2" port while 30"-54" valves utilize a 2" port. Please refer to option 202 (ex. 240A236106LN202) when ordering.

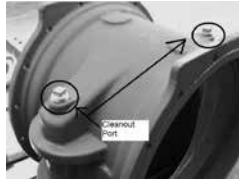

### Resilient Wedge and Double-Disc Gate Valve Options

#### Needle and Slot (Universal) Position Indicator

Can be furnished on 4" and larger non-rising stem valves with or without gearing. Mechanism is fully enclosed and uses a moving pointer on a scale to show relative position of valve gate.

#### Stainless Steel External Fasteners

Stainless steel (type 304 or 316) external fasteners are available.

*Note: Resilient Wedge Gate Valves through 12" have stainless steel type 304 fasteners as standard.*

### N.R.S. Bypass

Bypass valves are AWWA non-rising stem type. On resilient wedge valves, the bypass valve is also the RW type. On double-disc valves, it is the DD type. Bevel geared or horizontally installed valves have the bypass mounted on the bottom end of the valve. Spur geared or vertically installed valves have the bypass mounted on the disc of the valve body.



Available on 18"-54" Gate Valves Only.

Valve size/type	Bypass valve size
16" RW, FLxFL, MJxMJ, FLxMJ, end types only	2"
18"-20" RW	2"
24" RW	2-1/2"
30", 36" RW	3"
42"-54" RW	4"
14" DD	2"
16"-20" DD	3"
24", 30" DD	4"
36"	6"

### Gearing



Spur Gearing



Bevel Gearing

Non-rising stem gate valves 4" and larger can be furnished with bevel or spur gearing. Gearing is recommended for all resilient wedge gate valves 30" and larger, and for all double-disc gate valves 24" and larger. Gearing provides an additional bearing to support the extreme end of the valve stem. All gears have machine cut teeth. Bevel geared valves are for horizontal installation and spur geared valves for vertical. Styles shown are typical – actual appearance may vary.

### 2" Square Wrench Nut or Handwheel

The 2" square wrench nut is standard on all N.R.S. resilient wedge and double-disc gate valves except flange x flange and thread x thread valves, which have a handwheel as standard. The wrench nut and handwheel are optional alternatives to these standard features.

### How to order

Accessories are ordered by adding a suffix number to the basic gate valve catalog number. See chart below for accessory suffix numbers.

#### Catalog number for options\*

Catalog number suffix		Description	Valve size
Without indicator	With indicator		
02	102	Bevel gearing	4" and larger
03	103	Spur gearing	4" and larger
06	106	Bevel gearing and bypass	18"-54"
07	107	Spur gearing and bypass	18"-54"
09	-	Bypass only	18"-24"
-	108	Position indicator only	4"-24"

*\*Fasteners, coatings, operators and other options not included in this chart are ordered by including them in the valve specification notations.*

**Double-Disc Gate Valve Options**

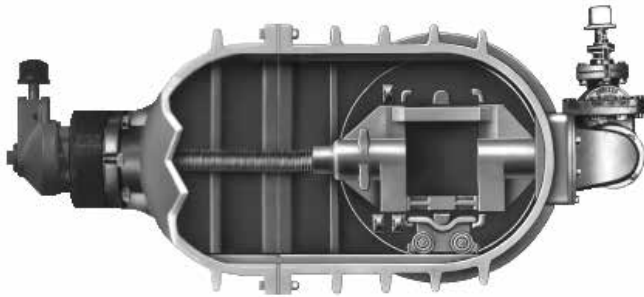

**Rollers, Tracks and Scrapers (Double-disc gate valves only)**

Double-disc gate valves in sizes 16" through 36" for vertical installations are furnished with a shoe on each side of the disc assembly for guiding the disc assembly throughout its entire travel. Gate valves in sizes 16" through 36" for horizontal installations are furnished with rollers which travel on a bronze track in the body and bonnet. These rollers support the weight of the disc assembly throughout its entire travel. The roller carriage has scrapers for cleaning the track ahead of the rollers. Rollers and tracks are required on 16" and larger double-disc gate valves when the main valve stem is horizontal. They are not required on bevel geared valves specified for vertical installation.

**Double disc gate valve o-ring conversion kit**

MUELLER CO. offers kits to convert non-rising stem conventionally packed gate valves to O-ring sealed type. The conversion replaces the conventional packing with two O-ring seals above the thrust collar and a gasket seal between the bonnet and new stuffing box.



**O-ring conversion kit contains the following**

- (1) G-70 Stuffing box
- (2) G-48 O-rings
- (1) G-32 Stuffing box gasket
- G-41 bolts and nuts
  - (2) for 2" valve
  - (4) for 3"-14" valves
  - (6) for 16"-24" valves

Valve Size	Conversion Kit Part Number
2"	181338
3"	181393*
4"	181340
6"	181341
8"	181342
10"	181343
12"	181344
14"	181388
16"	181389
18"	181390
20"	181391
24"	181392

\*1956 Design. For valves made prior to 1956 use kit number 181339

Rev. 4-14 Shaded area indicates changes

## Accessory Kits

Type	Part Number	Sizes*	Included
Flange end	A-199206	4"-12"	Flat gasket, bolts/nuts
MJ end - D.I.	A-199000	2", 3"-48"	Ring gasket, DI gland, bolts/nuts
MJ end - C.I.	A-199100	2", 3"-24"	Ring gasket, CI gland, bolts/nuts

NOTE: Basic kits listed here. Contact MUELLER Customer Service Center regarding the many options available.

## Slip - on Gaskets

Valve Size	Part Number
4"	195204
6"	195205
8"	195206
10"	195207
12"	195208
14"	348510
16"	199946

## Gland Packs

### Standard Mechanical Joint Accessories

Valve Size	Standard Mechanical Joint Gland Part Number	Gland with Bonding Set Screws Part Number	Plain Rubber Gasket Part Number
2"	155163	181299	194629
3"	155024	181301	194531
4"	155014	181302	194532
6"	155016	181303	194533
8"	155018	181304	194534
10"	155020	181305	194535
12"	155022	181306	194536
14"	155273	181307	194684
16"	155170	181308	194632
18"	155352	181314	194729
20"	155264	181309	194670
24"	155263	181310	194671
30"	155481	-	194779
36"	155079	-	194169

### Radial Compression Gaskets

Valve Size	Part Number
2"	195290
2-1/2"	195291
3"	195292
4"	195293
6"	195294
8"	348375

"T" Head Bolts and Nuts (size supplied will be appropriate for size of valve) - specify quantity

Valve Size	Part Number
2"	280035
3"	280036
4"	280037
4"	280042**
6"	280037
6"	200042**
8"	280038
8"	200043**
10"	280038
10"	280043**
12"	280038
12"	280043**
14"	280038
16"	280039
18"	280039
20"	280039
24"	280040
30"	280041
36"	280041

\* Nominal  
\*\* Anti-rotation bolts

## Gland Packs

### D-150 Mechanical Joint Accessories

Valve Size	D-150 Mechanical Gland Joint Part Number	D-150 Mechanical Joint Gland with Bonding Screws Part Number	D-150 Plain Gasket Part Number	D-150 Duck-tipped Gasket Part Number
4"	160519	186610	194738	194732
6"	160520	186611	194739	194733
8"	160521	186612	194740	194734
10"	160522	186613	194741	194735
12"	160523	186614	194742	194736



# GATE VALVE ORDERING INSTRUCTIONS



# 10.53

Shaded area indicates change Rev. 4-14

---

## To order Gate Valves specify:

### Quantity

If more than one size, specify quantity of each

---

### Size

Nominal size of valve

---

### Catalog number

---

### Special catalog number suffix

See chart at bottom of page 10.40 if gearing, grease cases, bypass valves or position indicators are required. The appropriate suffix number is added to the base catalog number.

---

### Direction of opening

Specify open left (counter-clockwise) or open right (clockwise). Wrench nuts on valves that open to the right are painted red for identification purposes.

---

### Method of operation

N.R.S. valves are available with either a 2" square wrench nut or a handwheel. Handwheels are standard on flanged x flanged and thread x thread valves; all other NRS\* valves have a 2" square wrench nut as standard. Outside screw and yoke type valves are available with handwheel only. When ordering NRS valves, specify wrench nut or handwheel.

\* 30"-54" resilient wedge and double-disc gate valves must be ordered with actuator.

---

### Special Requirements

Contact MUELLER Customer Service Center with special requirements such as special paints or coatings, low zinc bronze stems, stainless steel fasteners etc.

---

### Gate Valve Repair Parts

To order repair parts specify size of valve, direction of opening, year date on body, part number, catalog number of valve if known, and type of ends if ordering body.

---

Rev. 7-14 Shaded area indicates changes

### Resilient seat valve parts

Catalog Part No.	Description	Material	Material Standard
G-1	Cap nut	Bronze	ASTM B62
G-2	Key	Steel	-
G-3	Handwheel	Cast Iron	ASTM A126 CL.B
G-4	Washer	Brass	-
G-5	Bush nut	Bronze	ASTM B62
G-7	Gland nut	Bronze	ASTM B21 Alloy 464
G-9	Gland	Bronze	ASTM B62
G-10	Gland bolt	Steel	ANSI B18.2.1
G-11	Yoke bolt and nut	Steel	ANSI B18.2.1
G-16	Bonnet bolts and nuts	Steel	ANSI B18 2.1 plated
G-23	Stem packing	Lubricated flax	-
G-24	Test plug	Iron	-
G-26	Nut for wrench nut	Steel	ANSI B18 2.1 plated
G-32	Stuffing box gasket	Fiber	-
G-38	Wrench nut	Cast Iron	ASTM A126 CL.B
G-41	Stuffing box bolt and nut	Steel	ANSI B18 2.1 plated
G-42	Stem	Bronze	ASTM B138
G-45	Handwheel	Cast Iron	ASTM A126 CL.B
G-48	Stuffing box o-ring	Rubber	ASTM D2000
G-49	Stem o-ring	Rubber	ASTM D2000
G-176	Anti-friction washer	Acetal	-
G-178	Seat ring	Rubber	ASTM D2000
G-179	Retaining screw	Stainless Steel	-
G-181	Bonnet gasket	Composition	ASTM D1170
G-183	Stem	Bronze	CDA Alloy 676
G-184	Pin	Bronze	-

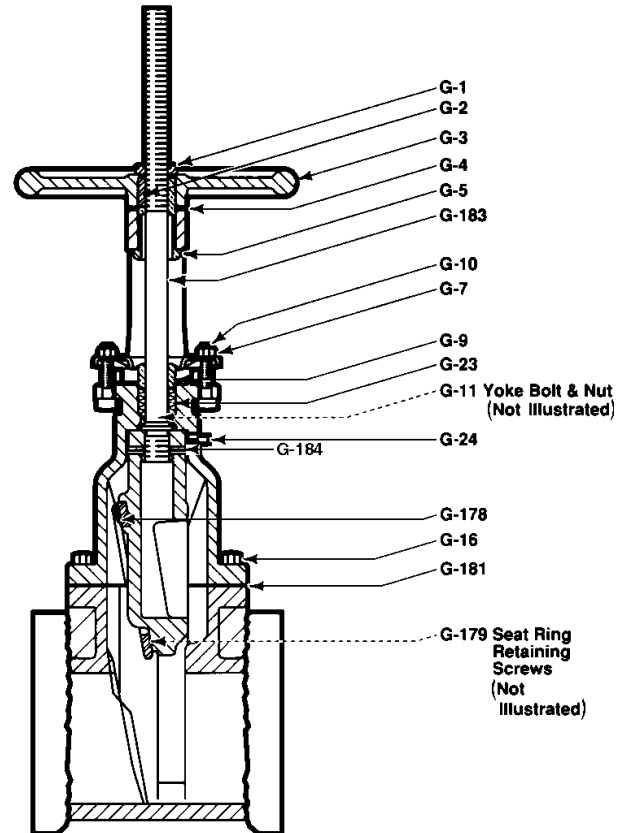
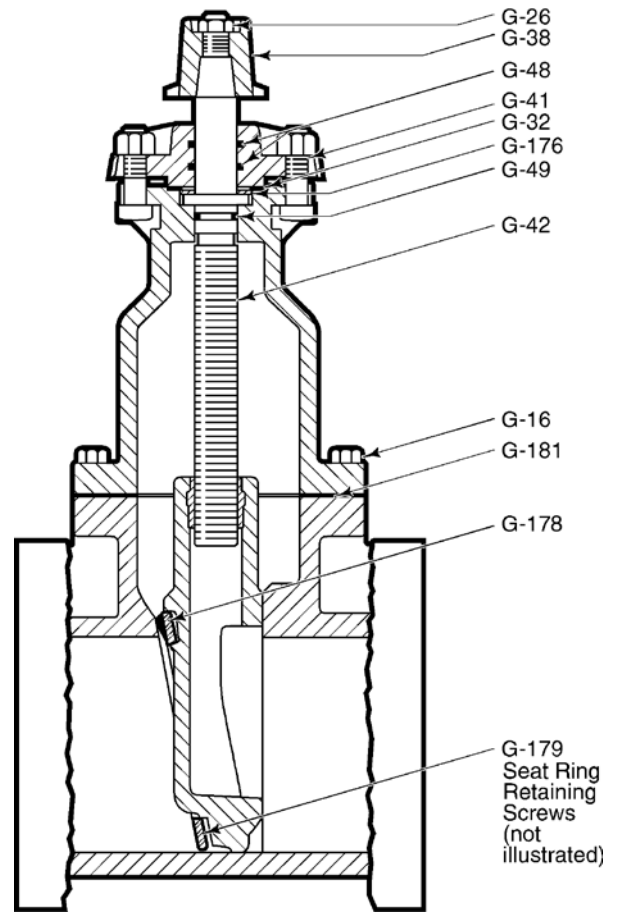



**Reliable Connections™**

[www.muellercompany.com](http://www.muellercompany.com)  
[moreinfo@muellercompany.com](mailto:moreinfo@muellercompany.com)

---

Rev. 7-16 Shaded area indicates changes

- Catalog number – **A-2362-37** radial compression ends
- Sizes – 4", 6", 8"
- Meets or exceeds all applicable requirements of ANSI/AWWA C509 and C515, UL 262 Listed, FM 1120/1130 Approved, and certified to ANSI/NSF 61
- Radial compression ends fit IPS PVC plastic pipe
- Ductile Iron body with nominal 10 mils **MUELLER® Pro-Gard®** Fusion Bonded Epoxy Coated interior and exterior surfaces
- Epoxy coating meets or exceeds all applicable requirements of ANSI/AWWA C550 Standard
- Iron wedge, symmetrical and fully encapsulated with molded rubber; no exposed iron
- Non-rising stem (NRS)
- Triple O-ring seal (2 above the thrust collar and 1 below)
- 2" square wrench nut - open left or open right
- 250 psig (1725 kPa/217 barg) maximum working pressure; 500 psig (3450 kPa/35 barg) static test pressure
- UL Listed, FM Approved: 200 psig (1375 kPa/14 barg)
- Mueller valves are designed for potable water applications



**A-2362-37**

### Options

See page 10.46 for more information on Resilient Wedge Gate Valve options

- Position indicators
- Stainless steel fasteners: Type 316
- ASTM B98-C66100/H02 stem
- Handwheel

### Resilient wedge gate valve parts

Catalog Part No.	Description	Material	Material Standard
G-16	Bonnet bolts and nuts	Stainless steel	Type 304
G-41	Stuffing box bolts and nuts	Stainless steel	Type 304
G-49	Stem O-rings (3)	Nitrile	ASTM D2000
G-200	Wrench nut cap screw	Stainless steel	Type 304
G-201	Stuffing box with seal	Cast iron + Nitrile	ASTM A126 CL.B ASTM D2000
G-202	Wrench nut	Ductile iron	ASTM A536 ▼
G-203	Stem	Bronze	ASTM B138
G-204	Handwheel (not shown)	Cast iron +	ASTM A126 CL.B
G-205	Stem nut	Bronze	ASTM B62
G-206	Guide cap bearings	Acetal	-
G-208	Anti-friction washers (2)	Acetal	-
G-209	Wedge Rubber Encapsulation	Ductile iron * SBR	ASTM A536 ▼ -
G-210**	Bonnet	Ductile iron	ASTM A536 ▼
G-211**	Bonnet O-ring	Nitrile	ASTM D2000
G-212**	Body	Ductile iron	ASTM A536 ▼

\* Fully encapsulated in molded rubber with no iron exposed  
 ▼ Material strength ASTM A536 65-45 minimum  
 + Manufacturer's option to upgrade material to ductile iron ASTM A536

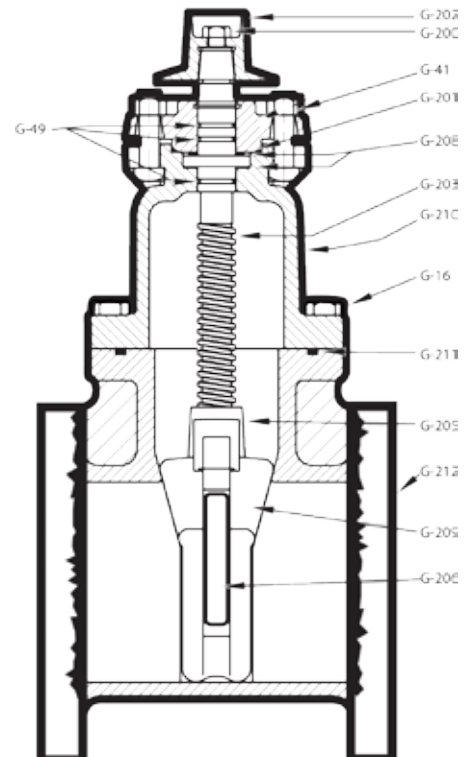

**4"-8" A-2361 RESILIENT WEDGE  
GATE VALVE - RAD. x RAD.**



**10.57**

Shaded area indicates change Rev. 1-16

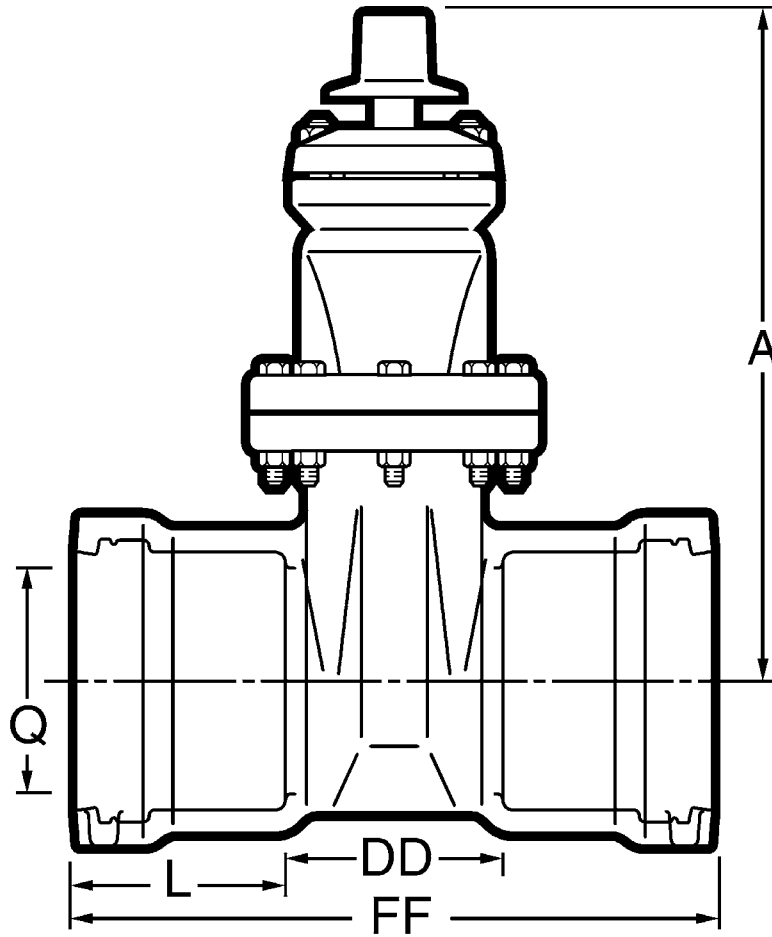

**Dimensions**

Dimension*	Nominal Size		
	4"	6"	8"
A	14.19	19.00	21.50
FF	13.43	15.91	18.40
L	4.46	5.46	6.20
Q (bore)	4.30	6.30	8.30
DD	4.51	4.99	6.00
Turns to open	14	20.5	26.5
Weight*	96	155	260

\*All dimensions are in inches. All weights are in pounds and are approximate.

Rev. 7-16 Shaded area indicates changes

- Catalog number–  
**A-2360-8** threaded ends
- Sizes – 2", 2-1/2", 3"
- Meets or exceeds all applicable requirements of ANSI/AWWA C509 Standard, UL 262 Listed, FM 1120/1130 Approved, and certified to ANSI/NSF 61
- Threaded end dimensions comply with ANSI B2.1
- Iron body with nominal 10 mils MUELLER® Pro-Gard™ Fusion Bonded Epoxy Coated interior and exterior surfaces
- Epoxy coating meets or exceeds all applicable requirements of ANSI/AWWA C550 Standard
- Iron wedge, symmetrical and fully encapsulated with molded rubber; no exposed iron
- Non-rising stem (NRS)
- Triple O-ring seal (2 above the thrust collar and 1 below)
- 2" square wrench nut - open left or open right
- 250 psig (1725 kPa/17 barg) maximum working pressure; 500 psig (3450 kPa/35 barg) static test pressure
- 2-1/2"-3" size – UL Listed, FM Approved: 200 psig (1375 kPa/14 barg)
- Mueller valves are designed for potable water applications



**A-2360-8**

### Options

See page 10.46 for more information on Resilient Wedge Gate Valve options

- Position indicators
- Stainless steel fasteners: Type 316
- ASTM B98-C66100/H02 stem
- Handwheel

### Resilient wedge gate valve parts

Catalog Part No.	Description	Material	Material Standard
G-16	Bonnet bolts and nuts	Stainless steel	Type 304
G-41	Stuffing box bolts and nuts	Stainless steel	Type 304
G-49	Stem O-rings (3)	Nitrile	ASTM D2000
G-200	Wrench nut cap screw	Stainless steel	Type 304
G-201	Stuffing box with seal	Cast iron + Nitrile	ASTM A126 CL.B ASTM D2000
G-202	Wrench nut	Cast iron +	ASTM A126 CL.B
G-203	Stem	Bronze	ASTM B138
G-204	Handwheel (not shown)	Cast iron +	ASTM A126 CL.B
G-205	Stem nut	Bronze	ASTM B62
G-206	Guide cap bearings	Acetal	-
G-207	Stuffing box	Cast iron +	ASTM A126 CL.B
G-208	Anti-friction washers (2)	Acetal	-
G-209	Wedge Rubber Encapsulation	Cast iron * + SBR	ASTM A126 CL.B -
G-210	Bonnet	Cast iron +	ASTM A126 CL.B
G-211	Bonnet O-ring	Nitrile	ASTM D2000
G-212	Body	Cast iron +	ASTM A126 CL.B

\* Fully encapsulated in molded rubber with no iron exposed  
+ Manufacturer's option to upgrade material to ductile iron ASTM A536

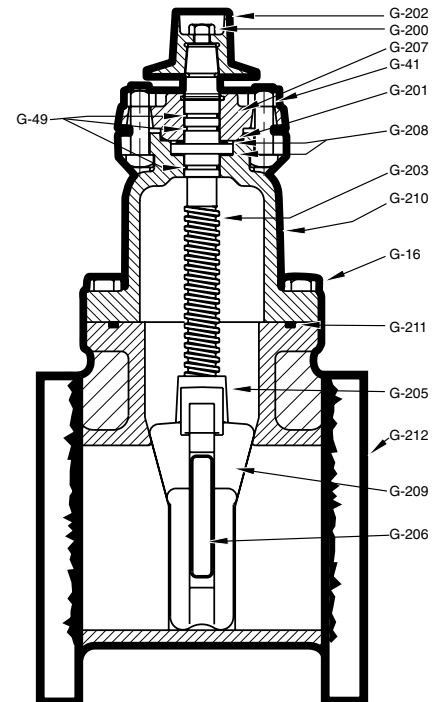

**2"-3" A-2360 RESILIENT  
WEDGE GATE VALVE - THD. x THD.**



**10.59**

Shaded area indicates change Rev. 9-14

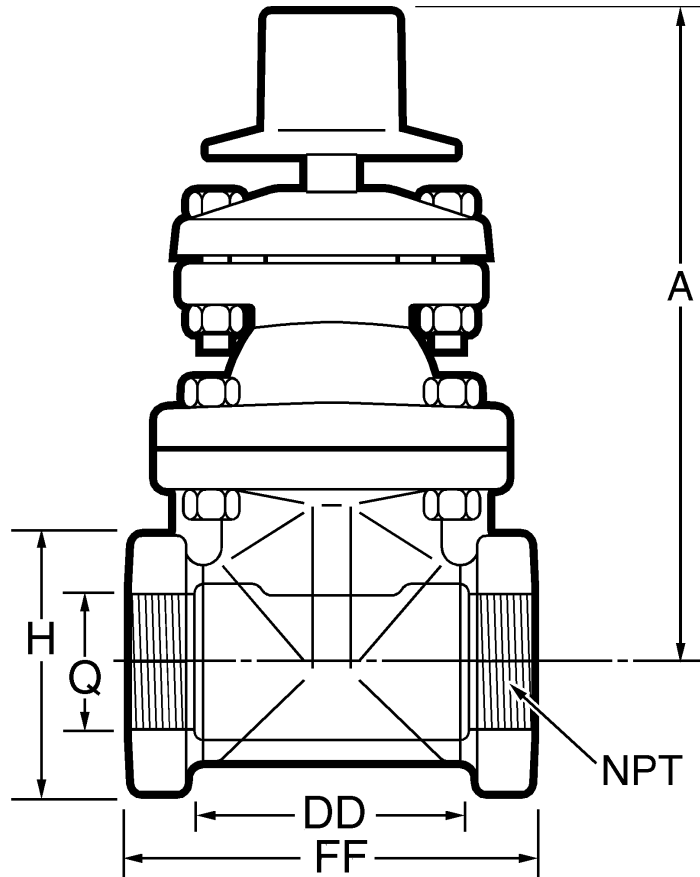

**Dimensions**

Dimension*	Nominal Size		
	2"	2-1/2"	3"
A	9.88	12.38	12.38
FF	5.88	5.88	6.88
Q (bore)	2.30	2.80	3.30
H ( hex across flats)	3.88	4.25	5.00
DD	4.12	4.12	5.12
Turns to open	8	11	11
Weight*	31	60	62

\*All dimensions are in inches. All weights are in pounds and are approximate.

Rev. 7-16 Shaded area indicates changes

- Catalog number – **A-2360-37** radial compression ends
- Sizes – 2", 2-1/2", 3"
- Meets or exceeds all applicable requirements of ANSI/AWWA C509 Standard, UL 262 Listed, FM 1120/1130 Approved, and certified to ANSI/NSF 61
- Radial compression ends fit IPS PVC plastic pipe
- Iron body with nominal 10 mils MUELLER® Pro-Gard™ Fusion Bonded Epoxy Coated interior and exterior surfaces
- Epoxy coating meets or exceeds all applicable requirements of ANSI/AWWA C550 Standard
- Iron wedge, symmetrical and fully encapsulated with molded rubber; no exposed iron
- Non-rising stem (NRS)
- Triple O-ring seal (2 above the thrust collar and 1 below)
- 2" square wrench nut - open left or open right
- 250 psig (1725 kPa/17 barg) maximum working pressure; 500 psig (3450 kPa/35 barg) static test pressure
- 2 1/2" - 3" sizes – UL Listed, FM Approved: 200 psig (1375 kPa/14 barg)
- Mueller valves are designed for potable water applications



**A-2360-37**

### Options

See page 10.46 for more information on Resilient Wedge Gate Valve options

- Position indicators
- Stainless steel fasteners: Type 316
- ASTM B98-C66100/H02 stem
- Handwheel

### Resilient wedge gate valve parts

Catalog Part No.	Description	Material	Material Standard
G-16	Bonnet bolts and nuts	Stainless steel	Type 304
G-41	Stuffing box bolts and nuts	Stainless steel	Type 304
G-49	Stem O-rings (3)	Nitrile	ASTM D2000
G-200	Wrench nut cap screw	Stainless steel	Type 304
G-201	Stuffing box with seal	Cast iron + Nitrile	ASTM A126 CL.B ASTM D2000
G-202	Wrench nut	Cast iron +	ASTM A126 CL.B
G-203	Stem	Bronze	ASTM B138
G-204	Handwheel (not shown)	Cast iron +	ASTM A126 CL.B
G-205	Stem nut	Bronze	ASTM B62
G-206	Guide cap bearings	Acetal	-
G-208	Anti-friction washers (2)	Acetal	-
G-209	Wedge Rubber Encapsulation	Cast iron * + SBR	ASTM A126 CL.B -
G-210**	Bonnet	Cast iron +	ASTM A126 CL.B
G-211**	Bonnet O-ring	Nitrile	ASTM D2000
G-212**	Body	Cast iron +	ASTM A126 CL.B

\*Fully encapsulated in molded rubber with no iron exposed

+ Manufacturer's option to upgrade material to ductile iron ASTM A536

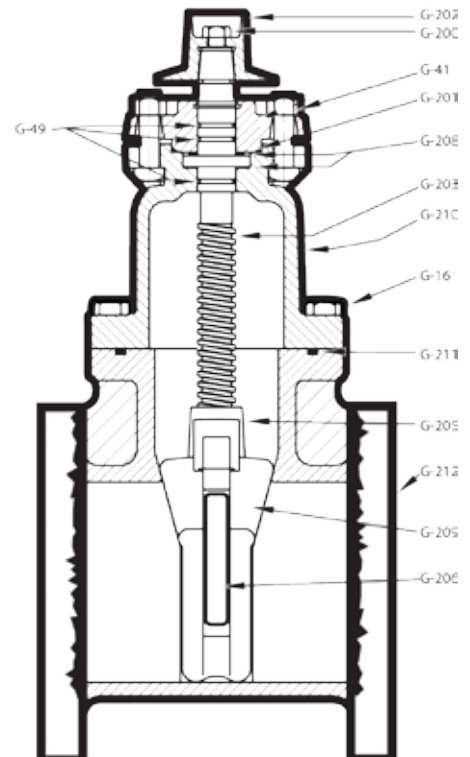



**2"-3" A-2360 RESILIENT WEDGE  
GATE VALVE - RAD. x RAD.**



**10.61**

Shaded area indicates change Rev. 1-16

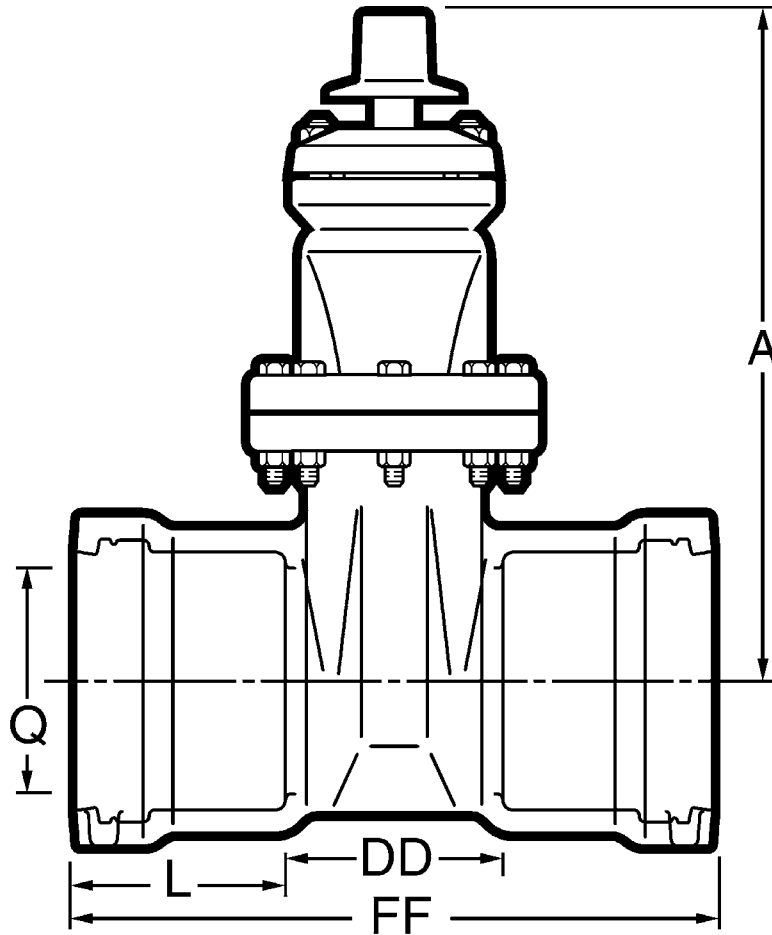

**Dimensions**

Dimension*	Nominal Size		
	2"	2-1/2"	3"
A	9.88	12.38	12.38
FF	10.25	10.75	11.75
L	3.50	3.69	4.12
Q (bore)	2.30	2.80	3.30
DD	3.25	3.37	3.51
Turns to open	8	11	11
Weight*	35	65	67

\*All dimensions are in inches. All weights are in pounds and are approximate.

10.62



MUELLER® GATE VALVES

Rev. 7-16 Shaded area indicates changes

---



**Reliable Connections™**

[www.muellercompany.com](http://www.muellercompany.com)  
[moreinfo@muellercompany.com](mailto:moreinfo@muellercompany.com)

---